

Needle Scalars

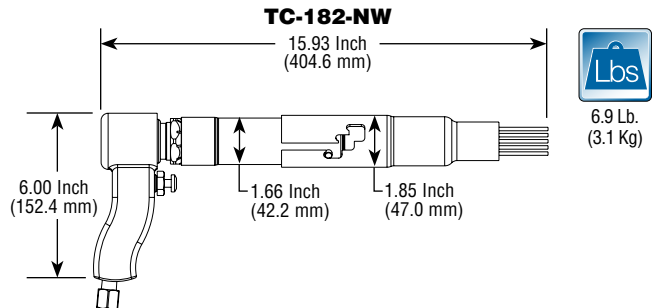

Air Inlet Size: 1/4" NPT
Hose Size Recommendations: 3/8" (10 mm)
Standard Equipment

• Tool • Operating Instructions and Service Manual

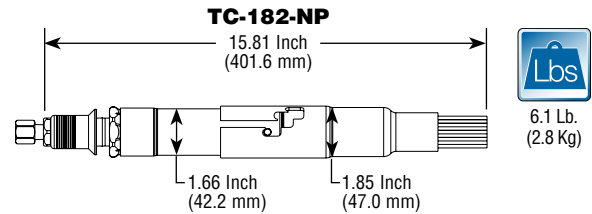
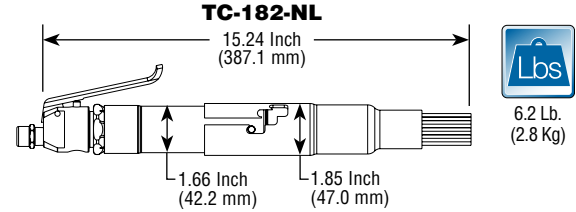

Quick Order Number

Model Number	Handle Style	Needle Length	Ordering Number
TC-182-N	Lever	5 Inch	TC-182-NL;5
		7 Inch	TC-182-NL;7
	Safety Lever	5 Inch	TC-182-NK;5
		7 Inch	TC-182-NK;7
	Push	5 Inch	TC-182-NP;5
		7 Inch	TC-182-NP;7
	Offset (Pistol)	5 Inch	TC-182-NW;5
		7 Inch	TC-182-NW;7

Top Cat® needle scalars are used to remove weld flux and peen strengthen welds. They can be easily converted to chisel scaler applications. Hardened alloy steel needles come as original equipment.



0.98 Inch x 1.06 Inches
(25.0 mm x 27.0 mm)



4000



20 cfm (9.4 L/s) Max

