

Bench Grinder

4 H.P. (3000 W)



66VBG

- Adjustable Spark Arrestor
- Adjustable Work Rest

Quick Order Number

Model Number	Operating Speed	Guard Size	Ordering Number
66VBG	6000 R.P.M.	9 Inch	66VBG;9
662VBG	3300 R.P.M.		662VBG;9

Other speeds are available. Please contact us for details.

This chart has been provided as a means to quickly identify a particular tool. The ordering numbers listed represent the most common versions of our tools.

Geared Tool Governor Controlled Tool

Air Inlet Size: 1/2" NPT Hose Size Recommendations: 1/2" (13 mm) Standard Equipment

- Tool
- Drive Flange Wrench
- Operating Instructions and Service Manual

This tool employs the higher speed production abrasive wheels normally used with pneumatic hand tools.

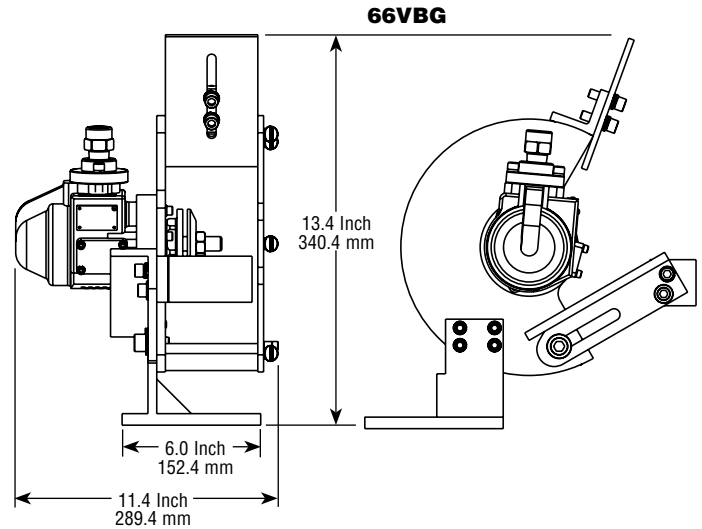

Spindle Output: 5/8-11



4.0 H.P.
(3000 W)



52.5 Lb.
(23.5 Kg)



25 cfm (11.8 L/s) Free Speed
75 cfm (35.4 L/s) Max

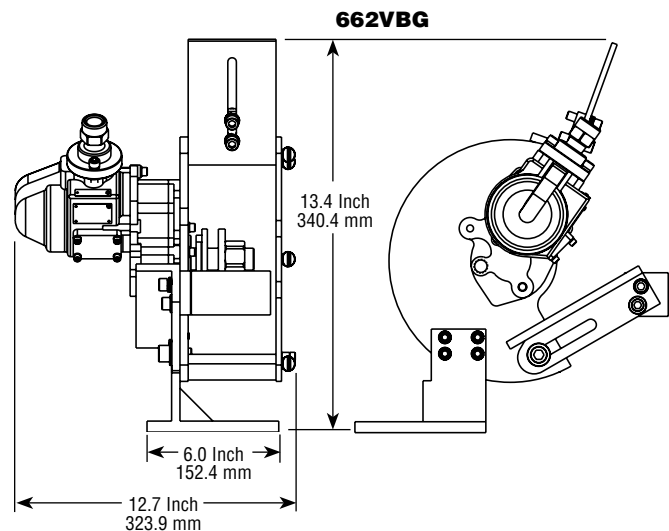

Spindle Output: 1.0-12



4.0 H.P.
(3000 W)



57.5 Lb.
(26.0 Kg)



25 cfm (11.8 L/s) Free Speed
75 cfm (35.4 L/s) Max