

5" (125 mm) - 9" (230 mm)
1.2 H.P. (900 W)

Right Angle Sanders for use with Abrasive Discs

Powerful 1.2 H.P. Motor w/ Large, Durable RA Head



Air Inlet Size: 3/8" NPT
Hose Size Recommendations: 1/2" (13 mm)
Extra Charge Accessories

- Safety Lever
- Standard Equipment**
- Tool • Operating Instructions and Service Manual
- 1 Wrench and 1 Pad Nut Wrench
- SPECIAL FEATURES**
- 1.2 H.P. Motor
- Dual Position Dead Handle Mount

Quick Order Number

This chart has been provided as a means to quickly identify a particular tool. The ordering numbers listed represent the most common versions of our tools. If more specialized versions are required, please build your model number per the following model number flow chart.

Model Number	Spindle Thread	Sanding Pad Size	Maximum Operating Speed	Throttle Type	
				Standard Throttle	Safety Throttle
4520RA	5/8-11	7 Inch	6000 RPM	4520RA;7SP	4520RAK;7SP
4620RA		5 Inch	10000 RPM	4620RA;5SP	4620RAK;5SP

The tools listed in this chart will be provided with an aluminum housing. Steel housing material is available. See information below for the entire spectrum of options available.



Front view of 4520RA/4527/4620RA/4627RA Series Tools

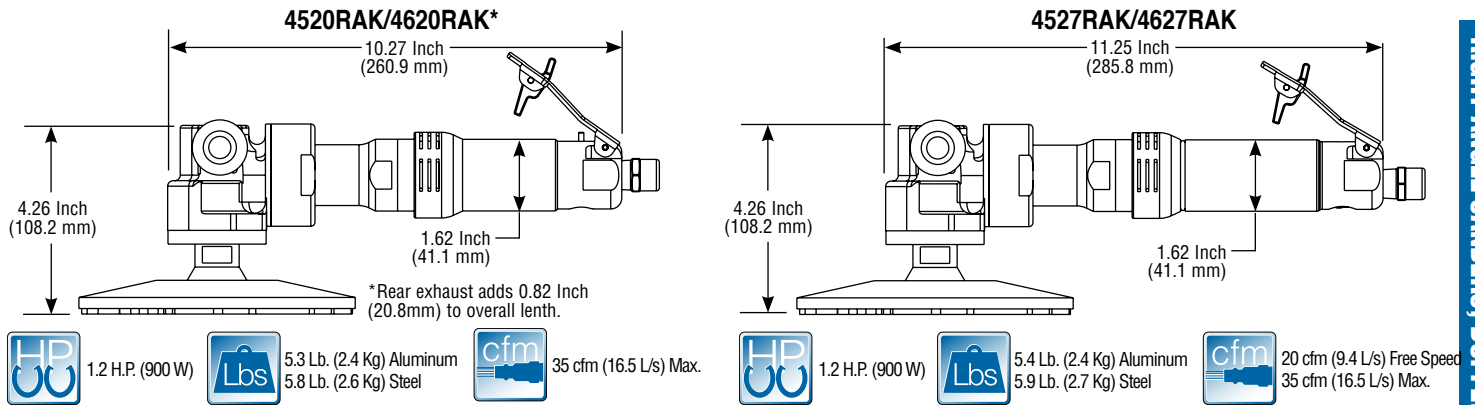

Example Model Number: **4101RA 2 K S R ; 15000**

The blue highlighted entries are shown in the Quick Reference Box above.

Model Number	Spindle Options	Lever Style	Case Material	Exhaust Direction	Operating Speed/Sanding Pad Size
4520RA				Please choose one of the following options: No Designation - Side Exhaust R - Rear Exhaust	6000 - 7SP - 6000 R.P.M.with 7 Inch Sanding Pad 6000 - 9SP - 6000 R.P.M.with 9 Inch Sanding Pad
4527RA	2 - 5/8-11 X 0.875	Please choose one of the following options: No Designation - Standard Lever K - Safety Lever	Please choose one of the following options: No Designation - Aluminum Case S - Steel Case	No Designation - Side Exhaust	6000-5000 - 7SP - 3000-5000 R.P.M.with 7 Inch Sanding Pad** 6000-5000 - 9SP - 3000-5000 R.P.M.with 9 Inch Sanding Pad**
4620RA				No Designation - Side Exhaust R - Rear Exhaust	12000 - 5SP - 12000 R.P.M.with 5 Inch Sanding Pad
4627RA				No Designation - Side Exhaust	9000-11000 - 5SP - 9000-11000 R.P.M.with 5 Inch Sanding Pad**

- ⚙️ Geared Tool
- ⚙️ Governor Controlled Tool

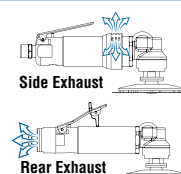

**The range offered reflects the minimum to maximum operating speeds that this tool can be set. One must choose a speed within this range that best fits the application. Please examine the abrasive used with the tool for a maximum operating speed. The tool should be set at or below the maximum operating speed listed on the abrasive.

WARNING: Follow all recommendations from component and abrasive manufacturers for speeds and proper usage.