

Right Angle Collet Grinders

0.4 H.P. – 0.7 H.P. (300 – 525 W)

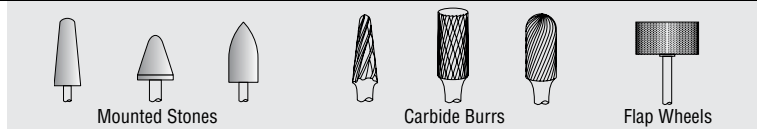

Air Inlet Size: 1/4" NPT
Hose Size Recommendations: 3/8" (10 mm)
Extra Charge Accessories

- Safety Lever
- Standard Equipment**
- Tool • Operating Instructions and Service Manual
- 2 Wrenches (sizes based on options)

RIGHT ANGLE GRINDERS

Quick Order Number				
Model Number	Collet Size	Maximum Operating Speed	Case Material	
			Aluminum	Steel
250RAD	1/4 Inch	20000 RPM	250RAD;1/4	250RADSK;1/4
300RAD			300RAD;1/4	300RADSK;1/4

All the versions listed in the table will be supplied with a standard lever throttle (class 1). A safety lever throttle (class 2) is also available.

This chart has been provided as a means to quickly identify a particular tool. The ordering numbers listed represent the most common versions of our tools. If more specialized versions are required, please build your model number per the following model number flow chart.

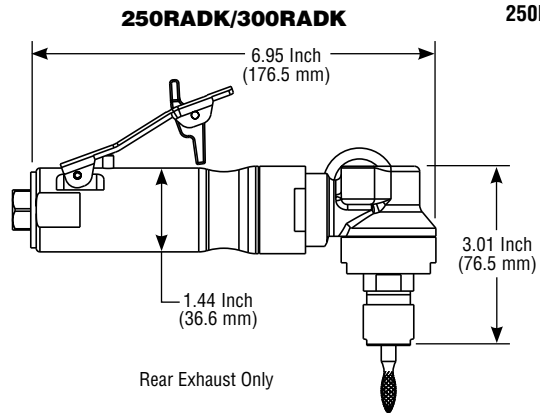

- Front view of 250RAD/300RAD Series Tools**
- HP** 250RAD - 0.4 H.P. (300 W)
300RAD - 0.7 H.P. (525 W)
 - Lbs** *Aluminum* 250RAD - 2.5 Lbs. (1.1 Kg)
Steel 300RAD - 2.0 Lbs. (0.9 Kg)
 - cfm** 250RAD - 18 cfm (8.5 L/s)
300RAD - 25 cfm (11.8 L/s)

Example Model Number: **250RAD K S ; 20000 ; 1/4**

The blue highlighted entries are shown in the Quick Reference Box above.

Model Number	Lever Style	Case Material	Operating Speed	Collet Size
250RAD	Please choose one of the following options: No Designation - Standard Lever K - Safety Lever	Please choose one of the following options: No Designation - Aluminum Case S - Steel Case	20000 : 20000 R.P.M.	Please choose one of the following options: 1/8 - 1/8 Inch Collet 1/4 - 1/4 Inch Collet 3/8 - 3/8 Inch Collet 3MM - 3mm Collet 6MM - 6mm Collet 8MM - 8mm Collet
300RAD			15000 : 15000 R.P.M.	



WARNING: Follow all recommendations from component and abrasive manufacturers for speeds and proper usage.