

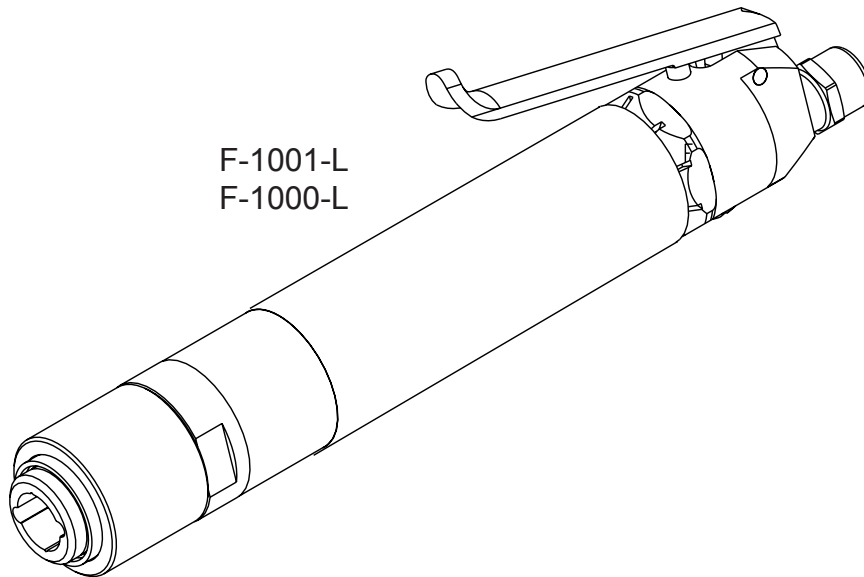

### General Operators Instructions and Maintenance Manual

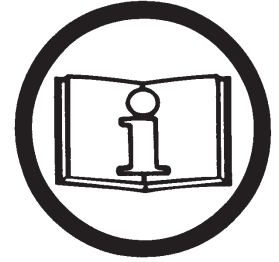

F-1001-L  
F-1000-L

F-1000 / F-1001 Series Scalers							
Model Number	Throttle Type	Bore and Stroke	Blows per Minute	Weight	Overall Length	Housing Diameter	Working Air Consumption
F-1000-L / F-1001-L	Lever	0.94 Inch x 2.0 Inch 24 mm x 51 mm	3500	4.9 Lb.(2.2 Kg)	10.8 Inch (275mm)	1.6 Inches (41 mm)	20 CFM (9.4 L/S)
F-1000-P / F-1001-P	Push			4.8 Lb.(2.2 Kg)	11.4 Inch (290mm)		
F-1000-W / F-1001-W	Offset			4.9 Lb.(2.2 Kg)	11.4 Inch (290mm)		

Read Safety Recommendations Before Operating Tool

# Operators Instructions and Safety Precautions

This is meant to highlight sections of safety standards published by the American National Standards Institute and the Occupational Safety and Health Administration. This is not meant to replace those standards but only highlight certain areas.

When care is taken to ensure that the right tool is operated properly, and safety and maintenance procedures are followed, accidents can be avoided. Read and follow all instructions and directions. Comply with all rules governing the use of power tools, personal protective equipment and equipment guards.

Remember - machines, attachments and accessories must be used only for the purpose for which they were designed. Safety reasons and product liability prohibit any modifications to tools. Any attachments or accessories must be agreed to in advance with an authorized technical representative of T.C. Service Co.



Always wear eye and hearing protection, and when necessary, other personal protective equipment such as gloves, an apron, and helmet. Properly fitted protective clothing cushion the operator from vibration exposure and help prevent minor scrapes that might occur as a result of guiding the tool along the workpiece.

Additional information on eye protection is available in the following national regulatory standards.

- 1) Federal OSHA Regulations 29 CFR, Section 1910.133 (Eye and Face Protection)
- 2) ANSI Z87.1 (Occupational and Educational Eye and Face Protection)



Airborne particulate resulting from the metal removal process can cause hazards. Wear appropriate protective equipment.

Check hose size and air pressure. The air pressure at the tool shall not exceed 90 psi (6.2 bar). All hoses should be inspected regularly and kept away from heat, oil and sharp edges. Be sure the tool is secured to the air hose.

Proper mounting of inserted tooling is crucial to safe operation and efficient working conditions. Ensure the exhaust air is directed away from bystanders.

Disconnect the tool from the air supply before doing any service. This prevents accidental start-ups.

# Safety in Operation

The safety procedures for operating air tools are everyone's responsibility. The following lists several aspects of air tool safety that should be considered during operation. Please be aware of these aspects and report any unsafe practice you see to a supervisor or safety officer immediately.

- 1) The inserted tool on heavy types of percussive, non-rotary power tools is exposed to heavy strains and can, after long period of use, break due to fatigue.
- 2) Unexpected tool movement or breakage of inserted tool may cause injuries to the lower limbs, in particular the feet.
- 3) Unsuitable postures may not allow counteracting of normal or unexpected movement of the power tool. (A working position shall be adopted which remains stable in the event of a break up of the inserted tool.)
- 4) Support the work piece properly.
- 5) Holding the inserted tool by the free hand can be a source of vibration damage.
- 6) If the tool jams, shut off the power and ease the chisel free. (Check the chisel for damage before continuing operation.)
- 7) Ensure that sparks from the process do not create a hazard to eyes or will ignite the environment.
- 8) Percussive tools shall not be used in potentially explosive atmospheres.
- 9) Pneumatically driven tools are not generally insulated from coming into contact with electric sources. Be sure to avoid contact with wires or other possible current carrying sources.
- 10) The operator must check that no bystanders are in the vicinity.
- 11) Disconnect the power supply before servicing and changing of inserted tooling.
- 12) Release control device in case of interruption of energy supply.
- 13) Always keep the tool in a clean, dry place when not in use.
- 14) Do not hold tool near body when operating.
- 15) Keep a firm grip on tool during operation.
- 16) Do not chisel toward your body.
- 17) If a quick disconnect hose fitting is used, insert a whip hose between coupling and the tool.
- 18) Never carry a tool by the hose.
- 19) Never yank the hose to disconnect it from the air supply.
- 20) Keep hoses away from heat, oil, sharp edges and in good repair - inspect regularly.
- 21) Check to see that tool is securely fastened to air hose.
- 22) In air hoses larger than ½ inch, a safety excess flow valve must be installed at the source of the air supply to reduce pressure in case of hose failure.
- 23) Before operating the tool, see that a safety clip or retainer is installed and working to prevent attachments such as chisels, needles or other implements from being ejected from the tool when operated. Because these retaining devices receive substantial abuse and wear, they should be inspected regularly and replaced when damage or wear is noted.
- 24) Never leave a tool attached to supplied air unattended. Avoid accidental actuation.
- 25) Always disconnect the tool from the air supply or shut off and drain the air hose prior to changing chisels, needles or other implements.
- 26) Never point or direct a tool toward another worker or yourself.
- 27) When working in close proximity to other workers, suitable barriers may need to be erected around work areas to protect workers from possible tool ejections or flying pieces from the removal process itself.
- 28) Be sure to wear the properly fitted personal protective equipment required to guard against operator injury.

# Maintenance

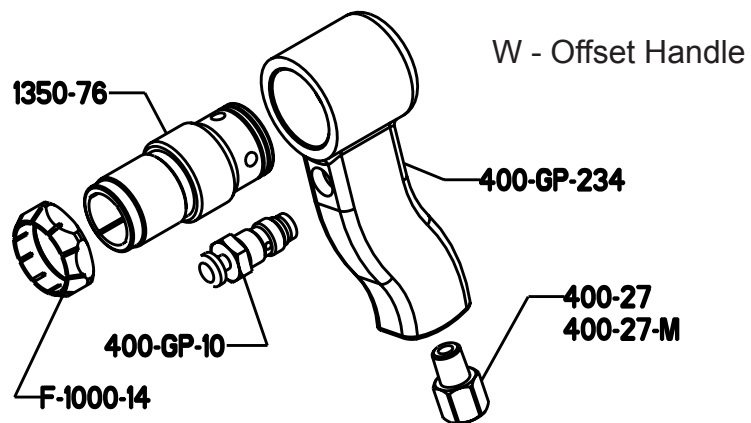
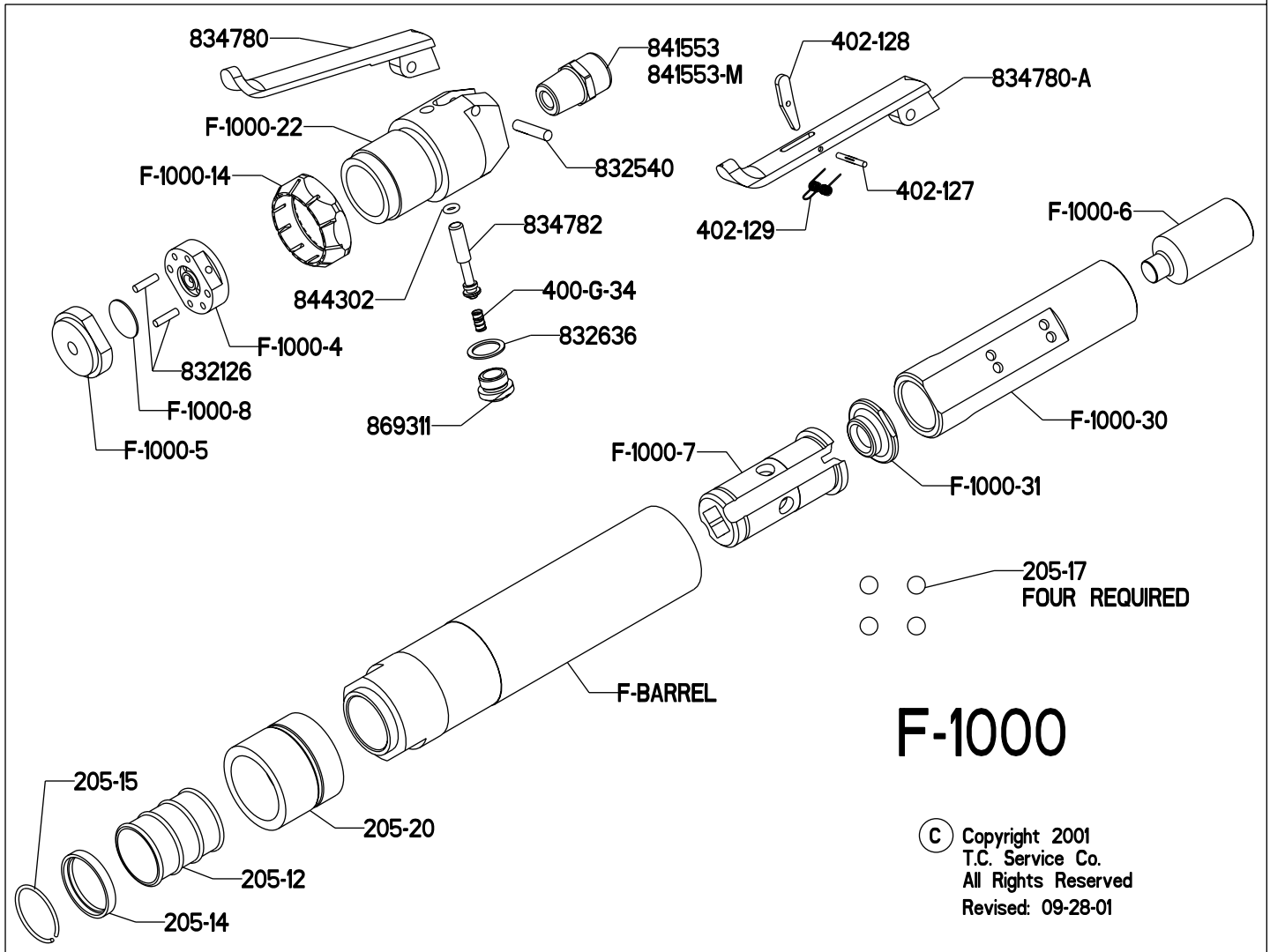

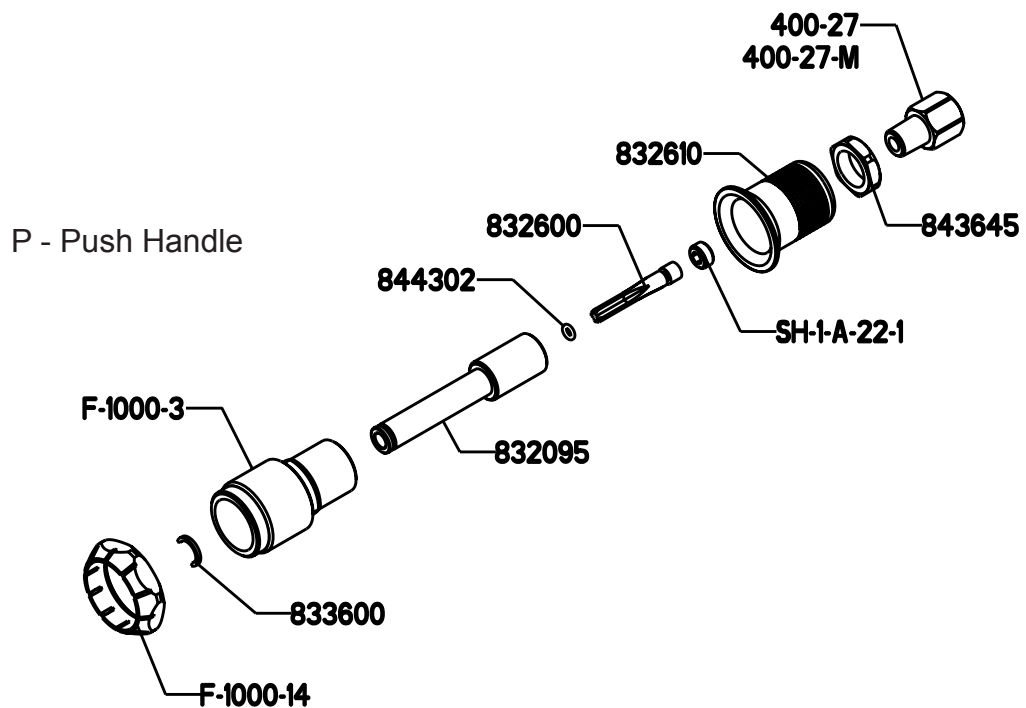
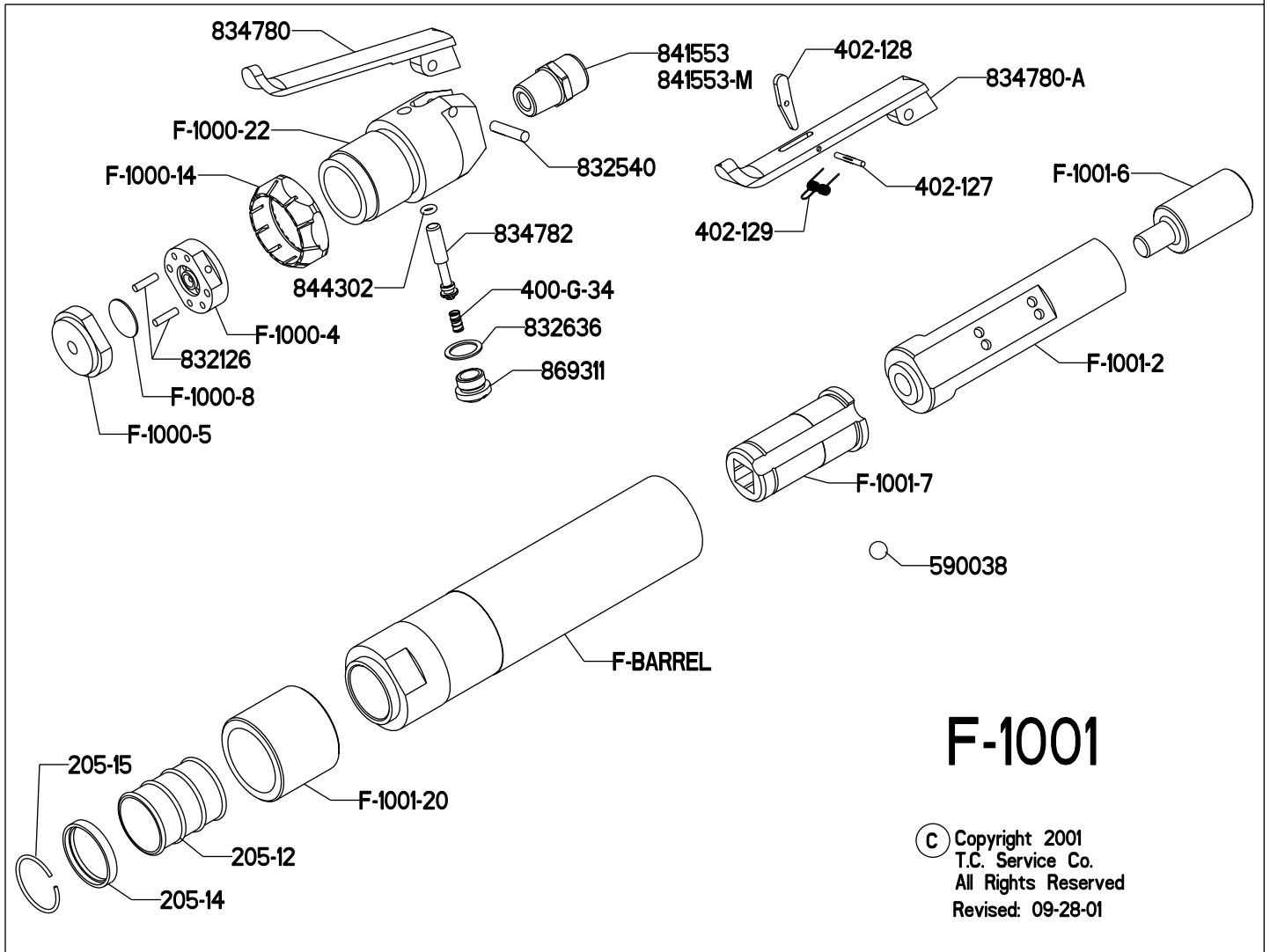

## **Disassembly**

1. Disconnect air and remove all accessories.
2. Position tool in vise vertically. Clamp onto flats of back head (F-1000-22) with the front end oriented toward upward direction.
3. Press washer (205-14) and spring (205-12) down inside collar (205-20{F-1000}/F-1001-20{F-1001}) with the use of two screw drivers (one in each hand). Hold in place with one screw driver. Remove lock ring (205-15).
4. Carefully release washer and spring then remove collar and retaining ball(s) (590038{F-1000}/205-17{F-1001}). Remove tool from vise.
5. Clamp the barrel assembly in the vise vertically with the front of tool oriented toward the downward direction. Clamp onto the flats on the front of the barrel (F-BARREL).
6. Loosen the lock ring (F-1000-14) with use of a wrench.
7. Loosen and remove backhead assembly from tool.
8. Remove barrel assembly from vise.
9. Slide the valve assembly and piston (F-1000-6{F-1000}/F-1001-6{F-1001}) from barrel of tool.
10. To check throttle valve, remove throttle valve cap (869311). Lift out gasket (832636), throttle valve spring (400-G-34) and throttle valve (834782). Replace o-ring (844302) if cracked or torn.

Note: {F-1000} The tool nose (F-1000-7), liner cap (F-1000-31) and liner (F-1000-30) require a hydraulic press to remove. {F-1001} The tool nose (F-1001-7) and liner (F-1001-2) require a hydraulic press to remove. Please send the tool back to our factory in Cleveland, OH for replacement of these parts.

## **Assembly**

1. Make sure all parts are clean and free of abrasives.
2. Support the lower valve block (F-1000-5) under an arbor press.
3. Press the pins (832126) into the blind holes of the lower valve block until they bottom. (The blind holes are those that are parallel to the axis of the part. The pins should bottom with a shoulder in the bottom of the holes.)
4. Place the valve (F-1000-8) into the recessed center of lower valve block.
5. Place upper valve block (F-1000-4) onto valve assembly. Aligns the pins in the blind holes of the upper valve block. (The blind holes are those that are parallel to the axis of the part.)
6. Support the valve assembly on a small, round support that is smaller in diameter than the inside of the barrel. The lower valve block should be oriented toward the upward direction. Place the piston (F-1000-6{F-1000}/F-1001-6{F-1001}) onto the lower valve block. The protrusion on one end of the piston should be oriented toward the upward direction.
7. Slip the rear of the barrel (F-BARREL) over the valve assembly and piston until the valve assembly bottoms. Grasp the support fixture and barrel. Turn the barrel assembly over. (This technique of assembly will ensure the valve assembly does not separate during installation.)
8. Clamp the barrel assembly in the vise vertically with the front of tool oriented toward the downward direction. Clamp onto the flats on the front of the barrel.
9. Screw the lock ring (F-1000-14) onto the backhead assembly. The taper of the lock ring should be oriented toward the front of the backhead assembly.
10. Screw on and tighten backhead assembly into scaler barrel assembly. Tighten lock ring against barrel assembly.
11. Remove from vise and resecure tool into vise vertically with front of tool toward upward direction.
12. Place retaining ball(s) (590038{F-1000}/205-17{F-1001}) into slot. Position collar (205-20{F-1000}/F-1001-20{F-1001}) over tool nose. Slip spring (205-12) and washer (205-14) inside collar.
13. Force washer and spring down with screw driver and hold in place. Place lock ring (205-15) into groove and release washer.

# Tool Parts Listing

## F-1000

<u>PART NUMBER</u>	<u>DESCRIPTION</u>
205-12	SPRING
205-14	RETAINER WASHER
205-15	RETAINER CLIP
205-17	RETAINER BALL(4 REQUIRED)
205-20	RETAINER
832126	PIN (2 REQUIRED)
F-1000-4	UPPER VALVE BLOCK
F-1000-8	VALVE
F-1000-6	PISTON
F-1000-5	LOWER VALVE BLOCK
F-1000-7	TOOL NOSE
F-1000-30	LINER
F-1000-31	LINER CAP
F-BARREL	BARREL

## F-1001

<u>PART NUMBER</u>	<u>DESCRIPTION</u>
205-12	SPRING
205-14	RETAINER WASHER
205-15	RETAINER CLIP
590038	RETAINER BALL
832126	PIN (2 REQUIRED)
F-1000-4	UPPER VALVE BLOCK
F-1000-5	LOWER VALVE BLOCK
F-1000-8	VALVE
F-1001-2	LINER
F-1001-6	PISTON
F-1001-7	TOOL NOSE
F-1001-20	RETAINER
F-BARREL	BARREL

## L - LEVER BACKHEAD

<u>PART NUMBER</u>	<u>DESCRIPTION</u>
400-G-34	SPRING
832540	PIN
832636	GASKET
834780	LEVER
834782	THROTTLE VALVE
841553	SCREEN HANDLE BUSHING
841553-M	METRIC SCREEN
	HANDLE BUSHING
844302	O-RING
869311	THOTTLE VALVE CAP
F-1000-14	LOCK RING
F-1000-22	BACKHEAD

## BW - OFFSET BACKHEAD

<u>PART NUMBER</u>	<u>DESCRIPTION</u>
400-GP-10	TRIGGER
400-GP-234	HANDLE (INCLUDES TRIGGER)
400-27	SCREEN HANDLE BUSHING
400-27-M	METRIC SCREEN
	HANDLE BUSHING
1350-76	ADAPTER
F-1000-14	LOCK RING

## P - PUSH BACKHEAD

<u>PART NUMBER</u>	<u>DESCRIPTION</u>
SH-1-A-22-1	VALVE RETAINER
400-27	SCREEN HANDLE BUSHING
400-27-M	METRIC SCREEN
	HANDLE BUSHING
832095	THROTTLE VALVE CASING
832600	THROTTLE VALVE
832610	HANDLE
832882	LOCK RING
843645	LOCK NUT
844302	O-RING
F-1000-3	BACKHEAD
F-1000-14	LOCK RING

## K - SAFETY LEVER

<u>PART NUMBER</u>	<u>DESCRIPTION</u>
402-127	SAFETY PIN
402-128	SAFETY LATCH
402-129	SAFETY SPRING
834780-A	SAFETY LEVER

## ASSEMBLIES

<u>PART NUMBER</u>	<u>DESCRIPTION</u>
400-GP-234	OFFSET HANDLE ASSEMBLY
AA-F-1000-3	PUSH BACKHEAD ASSEMBLY
AA-F-1000-22	LEVER BACKHEAD ASSEMBLY
AA-F-1000-22-K	SAFETY LEVER
	BACKHEAD ASSEMBLY
AA-834780	SAFETY LEVER ASSEMBLY



# Ergonomics - Work Healthy

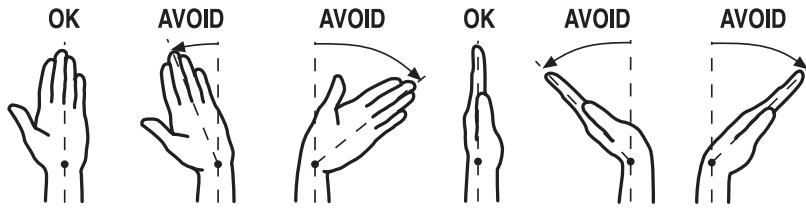

The following suggestions will help reduce or moderate the effects of repetitive work motion and/or extended vibration exposure:

- 1) Do not over-grip the machine/tool. Use only the force required to maintain control.
- 2) Keep hands and body dry and warm. (Blood flow is important - exercise hands and arms as often as necessary.)
- 3) Keep wrists as straight as possible. (Avoid hand positions that require the wrist to be flexed, hyper extended or turned side-to-side.)
- 4) Avoid anything that may inhibit blood circulation such as smoking tobacco or cold temperatures.
- 5) Do not support body-weight on the tool during operation.
- 6) Maintain a stress-free posture for the entire body.

Prolonged exposure to vibrations created by vibrating sources may cause health hazards. There are gloves, handle wraps and other forms of protective measures available to help reduce the hazard. The fit and condition of any vibration abatement measure must be monitored.

## Installation and Maintenance Tips

Following the guidelines will help you to ensure the pneumatic tools your company uses are operating and are maintained in the very best of condition.

### Initial Inspection of a New Tool

When a new tool is delivered to your facility, it is important to inspect the tool for any signs of damage that may have occurred during shipping. Here is a list of things to inspect:

- With the tool disconnected from the air supply, depress the throttle lever or trigger. The device should move freely and not become caught.
- Inspect the fit of the inserted tooling or needle driver into the tool. The inserted tooling or needle driver should fit properly into the front of the tool. It should move freely during installation and be fully retained when completely installed.

### Plumbing Installation

The tool must have fittings and connectors installed into the air inlet in order to connect with your company's air system. Your choice of fittings can greatly affect the performance of the tool.

#### Fitting Size

The size of the air inlet of the tool is the minimum size of fitting that will allow for proper airflow into the tool. Should a smaller fitting size be used such as reducers or adapters, this will constrict the airflow into the tool and reduce the overall performance.

### Coupling Size and Installation

The coupling size should be equal to or larger than the inlet size of the tool. If a smaller size coupling is used then the air supply volume may be reduced which may lead to reduced performance from the tool.



The coupling should be installed near to the tool. It is important that the tool receive internal lubrication on a regular basis. Having the connection closer to the tool will promote regular lubrication, as the connection is easily accessible. Hose whips are often used between the tool and the coupling.

Use thread sealant on all pipe threads and ensure a tight fit.

### Operation Test

After your initial inspection and installation of the plumbing connections, it is important to test for proper operation. Percussive tools for use with chisels will not function properly without an inserted tool or needle driver installed. Install a chisel or inserted tool into the front of the percussive tool and employ any safety retainers if the tool was so equipped. Needles scalers are designed to function with a front shell and a series of needles. The needle driver serves as the inserted tooling for this type of percussive tool. Support the inserted tool against a test plate and turn on the tool. The tool should begin a regular series of impacts. Run for a short time to ensure proper operation.

### Mounting Inserted Tooling

The mounting of the inserted tooling used with the tool is very important to ensure safety for the operator and proper functioning of the tool. The following diagrams briefly describe the methods and equipment for mounting most inserted tooling.

### Ensure Proper Pressure, Filtration & Lubrication

Properly lubricated pneumatic tools work better, last longer between maintenance intervals and are safer in general use. The maintenance costs are reduced dramatically when a little time is taken to regularly lubricate the tools. There are several ways to ensure proper lubrication.

#### 1) Filters, Regulators & Lubricators

These devices should be installed in the air system at each work station and inspected regularly to ensure proper operation. Each device in this set performs a vital task that greatly affects the performance of the tool and overall longevity of the component parts.

#### **Filters**

A filter is a device used to trap/contain particulate and liquid contaminants in the compressed air system. They generally have a cartridge or screen that requires cleaning or replacement regularly. Without this maintenance, the filtering device can become clogged and reduce the flow of air to the tool. A loss in performance can result.

#### **Regulators**

A regulator adjusts the operating pressure supplied to the tool. This device generally is used with a pressure gauge that will indicate the current pressure setting. All Top Cat ® pneumatic tools are designed to operate at 90 PSI (6.2 bar) while the tool is running. The tool should never be run if the pressure should exceed 90 PSI (6.2 bar).

#### **Lubricators**

Lubricators are devices that induce a controlled amount of oil into the air supply for pneumatically driven tools. They generally contain a reservoir that one must keep filled with oil. A light grade oil such as Mobil DTE light or equivalent is recommended. There is a variable setting on the lubricator that will determine the amount of oil induced into the air supply. It is important to inspect both the setting and amount of oil in the lubricator regularly to determine proper functioning of the device. The lack of oil in the air system will greatly reduce the performance and longevity of the pneumatically driven tool.

## 2) Direct injection of oil into the tool

A simple and easy way to ensure proper lubrication is to inject the oil directly into the tool air inlet. This should be performed prior to storage of the tool. To perform this task one must have a small container of the proper lubricating oil.

- Disconnect the tool from the air supply at the air coupling.
- Place a few drops of oil from the container into the air inlet of the tool directly.
- Reconnect the tool to the air supply.
- Direct the exhaust of the tool away from any bystanders or cover the exhaust with a shop rag.
- Run the tool until the oil has completely passed through the unit.

The best lubrication techniques include both methods.

### What Conditions Indicate the Need for Maintenance?

Pneumatic tools will exhibit several distinct signs that maintenance is required. Higher costs can be avoided if maintenance is performed when the first signs are evident. The following list details conditions that may indicate the necessity for service.

- 1) A reduction in power may indicate the necessity for maintenance.
- 2) Should the tool not maintain a uniform operating frequency, servicing may be required.

### **For More Information**

1) General Industry Safety & Health Regulations 29 CFR, Part 1910 and where applicable Construction Industry Safety & Health Regulations 29 CFR, Part 1926 available from Superintendent of Documents, Gov't. Printing Office, Washington, D.C. 20402.

2) Safety Code For Portable Air Tools, ANSI B186.1, B7.1 and Z87.1, available from American National Standards Institute, Inc. 1430 Broadway, New York, NY 10018

## F-1000/F-1001 Scalers

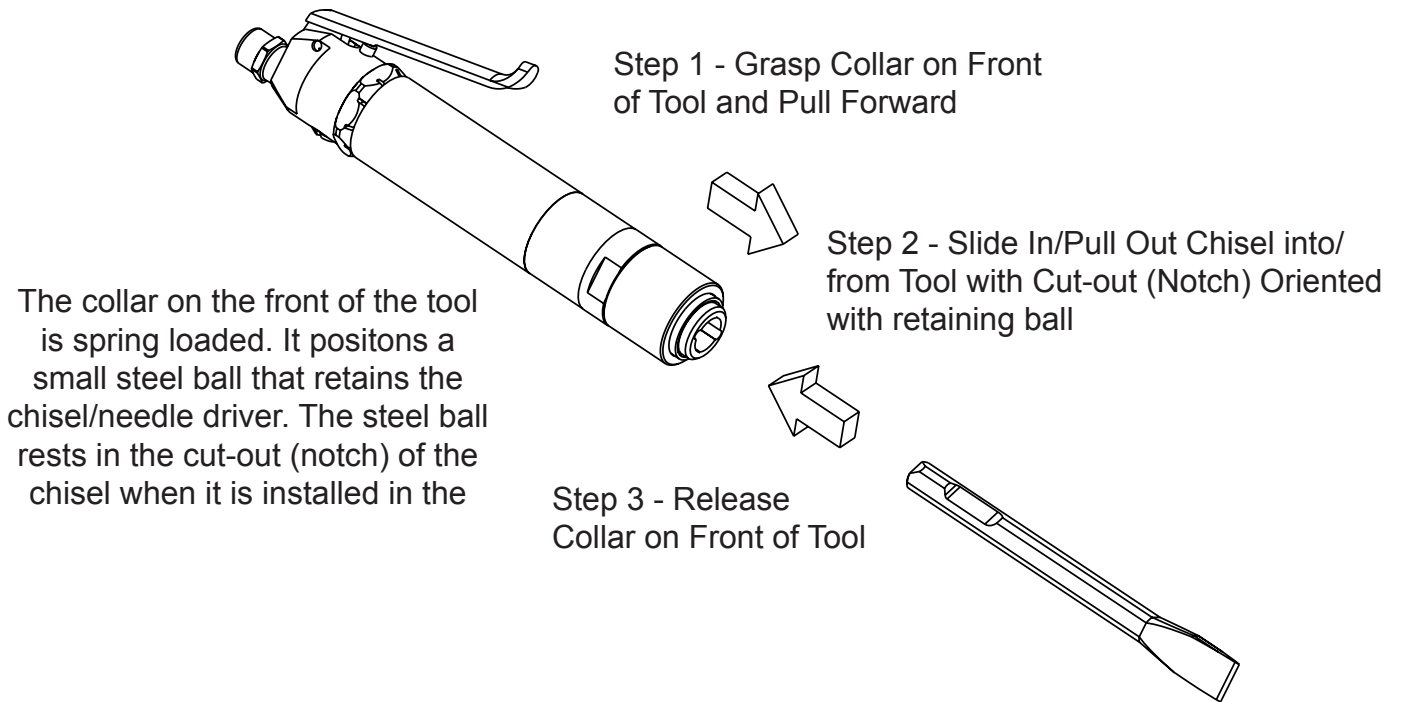

Note: The F-1000 tool accepts the 4-ball style chisel. this chisel has no orientation requirements ofr instalation. The F-1001 tool accepts the 1/4 octagon style chisel. This notch on the chisel must be aligned with the reatining ball in the front reatiner to be installed properly.



### **Grinders**

- Vertical Grinders
- Horizontal Grinders
- Right Angle Grinders
- Die Grinders
- Extended Grinders
- Bench Grinders

### **Polishers**

- Vertical Polishers
- Horizontal Polishers
- Right Angle Polishers

### **Percussion Tools**

- Scalers
- Needle Scalers
- Chipping Hammers
- Rammers

### **Saws**

### **Air Motors**



T.C. Service Co.  
38285 Pelton Rd.  
Willoughby, OH 44094  
U.S.A.  
Ph: 440-954-7500  
Fax: 440-954-7118

© Copyright 2004  
All Rights Reserved