

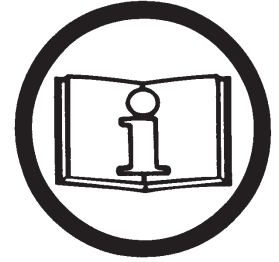

General Operators Instructions and Maintenance Manual

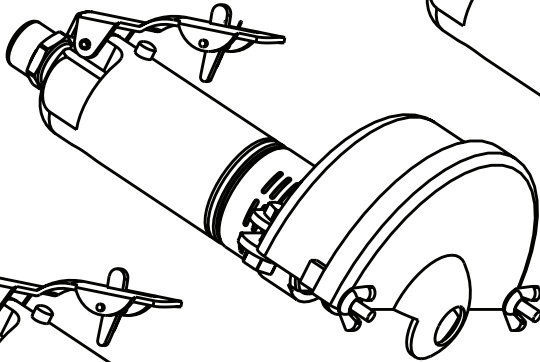

41AGK (TYPE 1)



41AGK+6

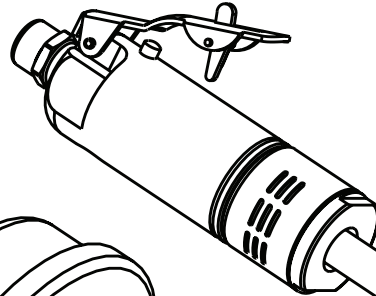

41AGK+3

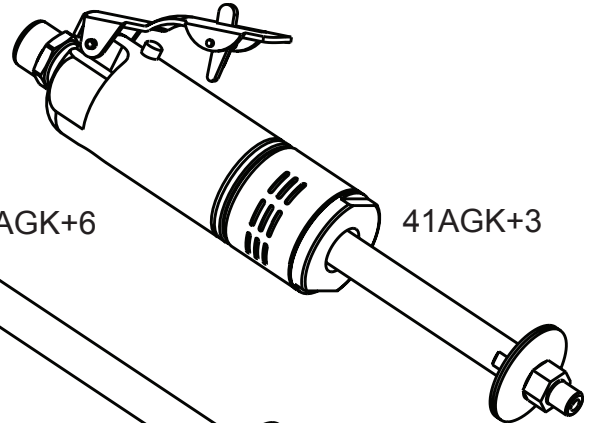

41AGK (COLLET)

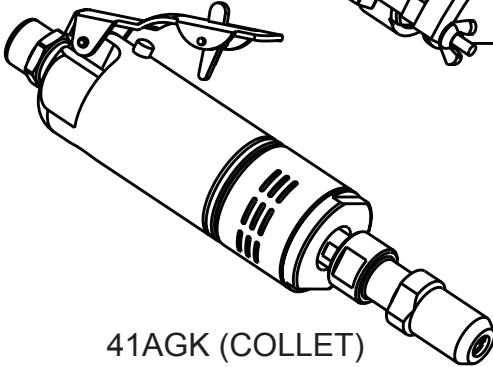

41AGKCW

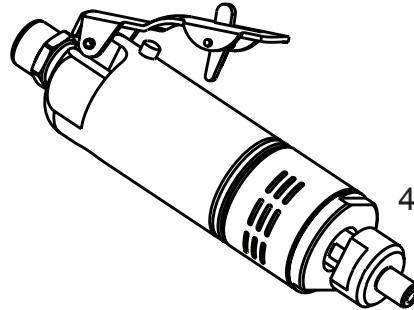

Read Safety Recommendations Before Operating Tool

Model Number	Exhaust Direction	Throttle Type	Rated Speed	Power Output	Case Material	Weight		Overall Length		Diameter	Working Air Consumption	Wheel capacity
						Aluminum	Steel					
41G	Front or Side	(L) Lever or (K) Safety Lever	15000 to 22000 R.P.M.	0.9 H.P. 675 W	Steel or Aluminum	1.5 lb/0.7 Kg	2.0 lb/0.9 Kg	6.9 inch	175 mm	1.6 inches 41 mm	25cfm 11.8 L/S	2" (50mm), 3" (75mm), or 4" (100mm)
41G+3						1.6 lb/0.7 Kg	2.0 lb/0.9 Kg	9.3 inch	236 mm			
41G+6						1.7 lb/0.8 Kg	2.1 lb/1.0 Kg	12.3 inch	312 mm			
41G-CW						1.5 lb/0.7 Kg	2.0 lb/0.9 Kg	5.8 inch	147 mm			

Capacity*

- 2 Inch (50mm), 3 Inch (75mm) or 4 Inch (100mm) Type 1 wheels
- Burrs/Mounted Stones of shank size 1/4 Inch, 3/8 Inch, 6mm or 8 mm
- Any Type 16, 17, 17R or 18R Cone Wheel with 3/8-24 mounting

*The +3 & +6 extended spindle versions of this tool are designed for polishing applications only.

Top Cat® Air Tools, Manufactured by T.C. Service Co.

38285 Pelton Road, Willoughby, OH 44094 U.S.A.

Ph: (440) 954-7500 or (800) 321-6876 • Fax: (440) 954-7118 or (877) 800-3589

E-Mail: sales@tcservice.com • Web Site: www.tcservice.com

Operators Instructions and Safety Precautions

This is meant to highlight sections of safety standards published by the American National Standards Institute and the Occupational Safety and Health Administration. This is not meant to replace those standards but only highlight certain areas.

When care is taken to ensure that the right tool is operated properly, and safety and maintenance procedures are followed, accidents can be avoided. Read and follow all instructions and directions. Comply with all rules governing the use of power tools, personal protective equipment and equipment guards.

Remember - machines, attachments and accessories must be used only for the purpose for which they were designed. Safety reasons and product liability prohibit any modifications to tools. Any attachments or accessories must be agreed to in advance with an authorized technical representative of T.C. Service Co.



The grinding equipment must be approved for the rated speed of the machine. The rated speed, marked on the machine, should not be exceeded. Be sure to learn the proper handling and storage of abrasive wheels and inserted tooling.

Inspect the wheel guard for any signs of wear and that it is properly mounted to the tool. Any guard showing signs of wear such as bends, chips, nicks, or cracks should be replaced.



Check hose size and air pressure. The air pressure at the tool shall not exceed 90 psi (6.2 bar). All hoses should be inspected regularly and kept away from heat, oil and sharp edges. Be sure the tool is secured to the air hose.

Measure the speed of grinders every 20 hours of actual use or once per week, whichever comes first.

Measure speed of all types of grinders after maintenance or repair, whenever a grinder is issued from the tool crib and at each wheel change. Several readings should be taken.

This form of inspection should be made with the grinding wheel or tooling removed.



Always wear eye and hearing protection, and when necessary, other personal protective equipment such as gloves, an apron, and helmet. Properly fitted protective clothing cushions the operator from vibration exposure and help prevent minor scrapes that might occur as a result of guiding the tool along the workpiece.

Additional information on eye protection is available in the following national regulatory standards.

- 1) Federal OSHA Regulations 29 CFR, Section 1910.133 (Eye and Face Protection)
- 2) ANSI Z87.1 (Occupational and Educational Eye and Face Protection)



Proper mounting of grinding wheels and inserted tooling is crucial to safe operation and efficient working conditions.

Ensure the exhaust air is directed away from bystanders.



Disconnect the tool from the air supply before doing any service. This prevents accidental start-ups.



Airborne particulate resulting from the grinding process can cause hazards. Wear appropriate protective equipment.

Safety in Operation

The safety procedures for operating air tools are everyone's responsibility. The following lists several aspects of air tool safety that should be considered during operation. Please be aware of these aspects and report any unsafe practice you see to a supervisor or safety officer immediately.

- 1) Start any new wheel under a bench and away from bystanders. (Run for a minimum of one minute.)
- 2) When starting a cold/new wheel, apply to the work slowly, allowing the wheel to warm gradually.
- 3) Support the work piece properly.
- 4) When cutting off, support the work piece so that a jamming of the wheel does not occur. (A Slot shall remain constant or become wider during operation.)
- 5) If a jamming of the wheel does occur during a cutting off operation, shut the air supply off to the tool and ease the wheel free. (Inspect the wheel for damage before continuing operation.)
- 6) Ensure that sparks from the process do not create a hazard to the eyes or will ignite the environment.
- 7) Grinders shall not be used in potentially explosive atmospheres.
- 8) Pneumatically driven tools are not generally insulated from coming in contact with electrical sources. Be sure to avoid contact with wires or other possible current carrying sources.
- 9) The operator must check that no bystanders are in the vicinity.
- 10) Remember that there is a running on after the throttle has been released.
- 11) If a grinder fitted with an abrasive wheel is dropped, the wheel must be thoroughly examined before re-use.
- 12) Disconnect the tool from the air source before servicing and changing wheels.
- 13) Release the control device in case of interruption of air supply.
- 14) Always keep the tool in a clean, dry place when not in use.
- 15) Beware of loose hair and clothing so as not to become tangled or trapped during operation.
- 16) Unexpected tool movement, or breakage of wheel or inserted tooling, may cause injury.
- 17) Unsuitable postures may not allow counteracting of normal or unexpected movement of a power tool. (A working position shall be adopted which remains stable in the event of a break up of inserted tooling.)
- 18) Do not hold the tool near the body when operating.
- 19) Keep a firm grip on the tool body during operation.

Maintenance

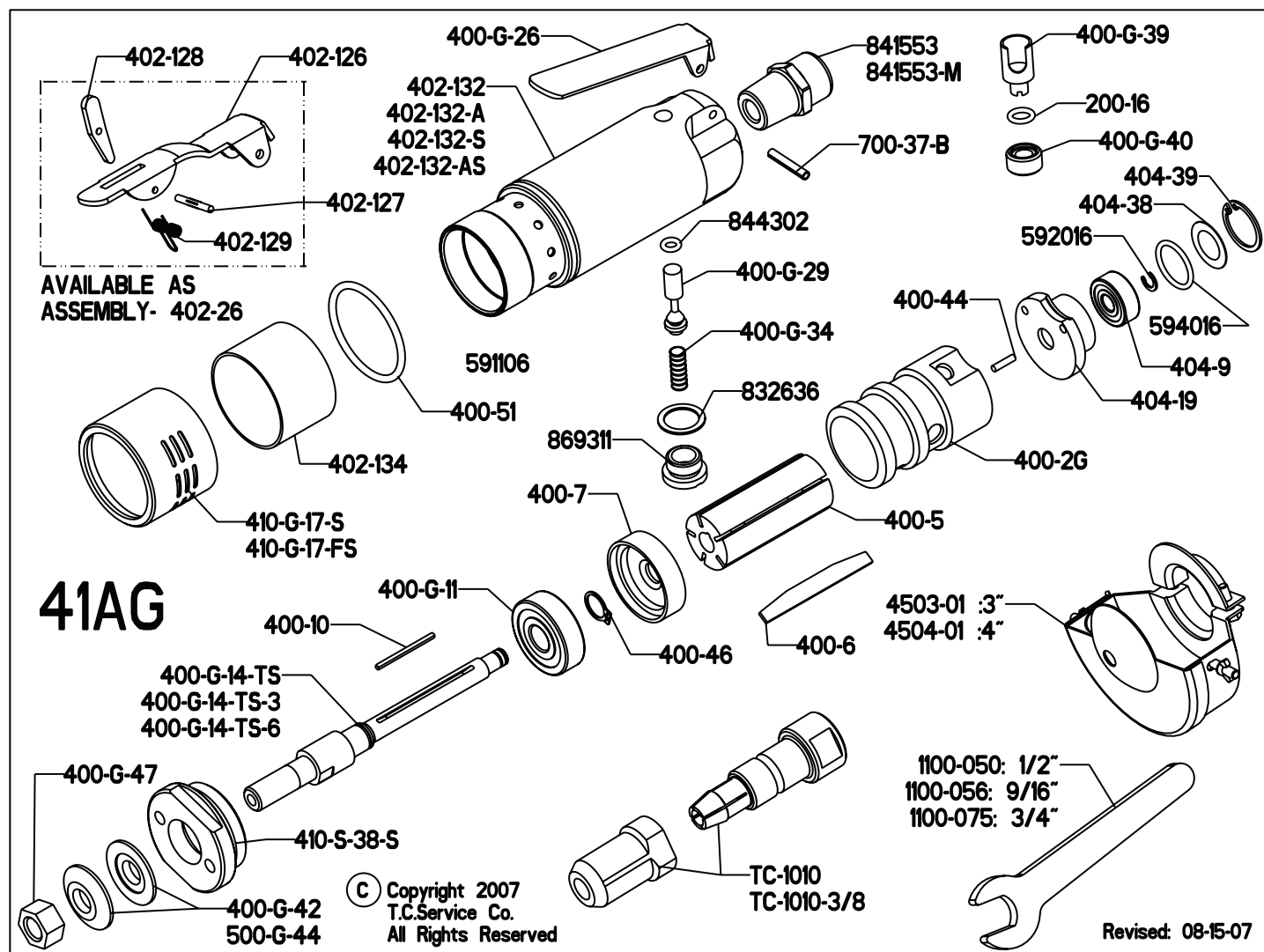

Disassemble

1. Disconnect air and remove all burrs, wheels and accessories.
2. Secure tool in vise vertically with output of tool oriented toward upward direction. Clamp onto the flats toward the rear of the motor housing.
3. Unscrew motor retainer (410-S-38-S) from motor housing (402-132{S}). Lift off exhaust deflector (410-G-17-S), exhaust screen (402-134) and o-ring (400-51) from motor housing. Remove motor from housing. Remove from vise.
5. Remove snap ring (404-39) from rear endplate (404-19) with snap ring pliers.
6. Lift out bearing cover (404-38) and o-ring (594016).
7. Slip retaining ring (592016) from groove of spindle (400-G-14-TS).
8. Install brass jaws on vise. Secure motor assembly into vise vertically with output toward downward direction. Clamp lightly the outside diameter of the cylinder (400-2G) and endplate (404-19).
9. Use a 3/16" punch to tap spindle out of rear bearing (404-9). Be careful not to drop the motor assembly when it is free. Remove from vise.
10. Use a small punch to press the rear bearing from the rear endplate.

11. Remove 5 blades (400-6), rotor (400-5) and key (400-10).
12. Remove front endplate (400-7).
13. Remove snap ring (400-46) from spindle with snap ring pliers.
13. Support the spindle assembly vertically on a suitable drill block. Press spindle through front bearing (400-G-11) with an arbor press.
14. To check throttle valve unscrew throttle valve cap (869311).
15. Lift out valve spring (400-G-34) and throttle valve (400-G-29). Remove and replace o-ring (844302) if cracked or worn.

Assembly

1. Be sure that all parts are clean and free of any abrasive.
2. Support bearing (400-G-11) on a suitable drill block.
3. Press spindle (400-G-14-TS) through bearing until it bottoms on shoulder.
4. Place retaining ring (400-46) into groove in spindle.
5. Slide front endplate (400-7) over spindle and onto front bearing.
6. Place key (400-10) into keyway in spindle.
7. Slide rotor (400-5) over spindle.
8. Place 5 blades (400-6) into slots.
9. Slip cylinder (400-2G) over rotor. (be sure the alignment pin is oriented away from the front for the motor assembly).
10. Install rear endplate (404-19) locating cylinder pin in smaller hole of the rear endplate.
11. Place bearing (404-9) in rear endplate. Tap in place with bearing driver (1100-803).
12. Place snap ring (592016) in spindle groove.
13. Place o-ring (594016), washer (404-38) and snap ring (404-39) into rear of end plate.
13. Secure motor housing (402-132[A][S][AS]) in vise vertically with output of tool toward upward direction. Clamp onto the flats toward the rear of the motor housing
14. Place o-ring (400-51), exhaust screen (402-134) and exhaust deflector (410-G-17-S) onto motor housing.
15. Slide front motor assembly into motor housing. Install motor retainer (410-S-38-S) and tighten.
- 16. Check the operating speed with a reliable tachometer. The speed must be at or below the stamped speed on the tool.**
- 17. Install all required guards and safety devices before returning tool to service.**

Tool Parts Listing

<u>PART</u>	<u>DESCRIPTION</u>	<u>TOOLS</u>	<u>DESCRIPTION</u>
200-16	O-RING	<u>PART</u>	
400-G-11	FRONT BEARING	490-3	PIN SPANNER
400-G-11A	SEALED FRONT BEARING	1100-050	1/2" WRENCH
400-G-14-TS	SPINDLE	1100-056	9/16" WRENCH
400-G14-TS-LH	LEFT HAND SPINDLE	1100-075	3/4" WRENCH
400-G14-TS+2.5	2.5" EXTENDED SPINDLE	1100-638	SPINDLE HOLDER
400-G14-TS+2.5-LH	2.5" LEFT HAND EXTENDED SPINDLE	1100-806	404-9 BEARING DRIVER
400-G14-TS+3	3" EXTENDED SPINDLE	1100-814	400-G-11 BEARING DRIVER
400-G14-TS+3-LH	3" LEFT HAND EXTENDED SPINDLE	541134	REGULATOR LOCK WRENCH
400-G14-TS+6	6" EXTENDED SPINDLE		
400-G-26	THROTTLE LEVER	<u>GUARDS</u>	
400-G-29	THROTTLE VALVE-INCLUDES 844302	<u>PART</u>	<u>DESCRIPTION</u>
400-G-34	SPRING	4502-01	2" TYPE 01 GUARD
400-G-39	REGULATOR	4503-01	3" TYPE 01 GUARD
400-G-40	REGULATOR LOCK	4504-01	4" TYPE 01 GUARD
400-G-42	FLANGE FOR 2"-3" WHEELS		
400-G-47	3/8-24 NUT	<u>ASSEMBLIES</u>	
400-G-47-LH	3/8-24 LEFT HAND NUT	<u>PART</u>	<u>DESCRIPTION</u>
400-2G	CYLINDER	510240	REPAIR KIT
400-2GC	CHROME CYLINDER	402-26	SAFETY LEVER ASSY.
400-2GR	REVERSE ROTATION CYLINDER	AA-402-132	ALUMINUM CASE ASSY.
400-5	ROTOR	AA-402-132-A	ADJUSTABLE ALUMINUM CASE ASSY.
400-6	BLADE (5 REQ)	AA-402-132-AK	ADJ. ALUM. SAFETY CASE ASSY.
400-7	FRONT ENDPLATE	AA-402-132-AS	ADJUSTABLE STEEL CASE ASSY.
400-10	KEY	AA-402-132-ASK	ADJ. STEEL SAFETY CASE ASSY.
400-44	ROLL PIN	AA-402-132-K	ALUMINUM SAFETY CASE ASSY.
400-46	SNAP RING	AA-402-132-S	STEEL CASE ASSY.
400-51	O-RING	AA-402-132-SK	STEEL SAFETY CASE ASSY.
402-126	SAFETY LEVER		SPECIFY SPEED FOR CASE ASSY.
402-127	SAFETY LEVER PIN		
402-128	LOCKOUT LEVER		
402-129	SAFETY LEVER SPRING		
402-132	ALUMINUM CASE (SPECIFY SPEED)		
402-132-A	ADJ. ALUM. CASE (SPECIFY SPEED)		
402-132-AS	ADJ. STEEL CASE (SPECIFY SPEED)		
402-132-FT	ALUM. FLOW THRU CASE (SPECIFY SPEED)		
402-132-S	STEEL CASE (SPECIFY SPEED)		
402-132-S-FT	STEEL FLOW THRU CASE (SPECIFY SPEED)		
402-134	MUFFLER		
404-9	REAR BEARING		
404-9A	SEALED REAR BEARING		
404-19	REAR ENDPLATE		
404-19R	REVERSE ROTATION REAR ENDPLATE		
404-38	BEARING COVER		
404-39	SNAP RING		
410-G-17F-S	STEEL FRONT EXHAUST SLEEVE		
410-G-17-S	STEEL SIDE EXHAUST SLEEVE		
410-S-38-S	STEEL MOTOR RETAINER		
500-G-44	FLANGE FOR 4" WHEELS		
700-37B	THROTTLE LEVER PIN		
592016	SNAP RING		
594016	O-RING		
832636	GASKET		
841552	3/8 NPT TO 3/8 NPT BUSHING		
841553	3/8 NPT TO 1/4 NPT BUSHING		
841553-M	3/8 NPT TO 3/8 BSP BUSHING		
844302	O-RING		
869311	THROTTLE VALVE CAP		

Tool Parts Listing

ACCESSORIES

<u>PART</u>	<u>DESCRIPTION</u>
400-76J	9/16 UNTHREADED SPACER
400-76J-3/8	3/8 UNTHREADED SPACER
400-77	3/8-24 THREADED 9/16 SPACER (FOR CONE WHEEL)
400-77J	3/8-24 THREADED 3/8 SPACER
400-78	3/8-24 TO 5/8-11 ADAPTER
1100-346	3/8-24 THREAD TO 1" WIDE WHEEL ADAPTER
530196	1/8" ROUNDED TAPER BURR
530198	1/8" TAPER BURR
530200	1/8" FLAME BURR
530202	1/8" BALL BURR
530204	1/8" CYLINDRICAL BURR
530208	1/4" BALL BURR
530210	1/4" CYLINDRICAL BURR
530212	1/4" TREE BURR
530214	1/4" FLAME BURR
	OTHER SIZE BURRS AVAILABLE

COLLET ASSEMBLIES

<u>PART</u>	<u>DESCRIPTION</u>
AA-209-1/8	3/8-24 ERICKSON 3 PIECE--1/8" INSERT
AA-209-3/16	3/8-24 ERICKSON 3 PIECE--3/16" INSERT
AA-209-1/4	3/8-24 ERICKSON 3 PIECE--1/4" INSERT
AA-209-5/16	3/8-24 ERICKSON 3 PIECE--5/16" INSERT
AA-209-3/8	3/8-24 ERICKSON 3 PIECE--3/8" INSERT
AA-209-6MM	3/8-24 ERICKSON 3 PIECE--6MM INSERT
TC-1010	3/8-24 TO 1/4" I.D.- 2 PIECE HEAVY DUTY
TC-1010-3/8	3/8-24 TO 1/4" I.D.- 2 PIECE HEAVY DUTY
TC-1010-6MM	3/8-24 TO 6MM I.D.- 2 PIECE HEAVY DUTY
TC-1010-8MM	3/8-24 TO 8MM I.D.- 2 PIECE HEAVY DUTY
	OTHER SIZES AVAILABLE

ERICKSON COLLET PARTS

<u>PART</u>	<u>DESCRIPTION</u>
209-B	3/8-24 COLLET BODY
209-1	COLLET NUT
209-1/8	1/8" INSERT
209-3/16	3/16" INSERT
209-1/4	1/4" INSERT
209-5/16	5/16" INSERT
209-3/8	3/8" INSERT
209-6MM	6MM INSERT
209-8MM	8MM INSERT
	OTHER SIZE INSERTS AVAILABLE



T.C. Service Co.
38285 Pelton Rd.
Willoughby, OH 44094
U.S.A.
Ph: 440-954-7500
Fax: 440-954-7118

Ergonomics - Work Healthy

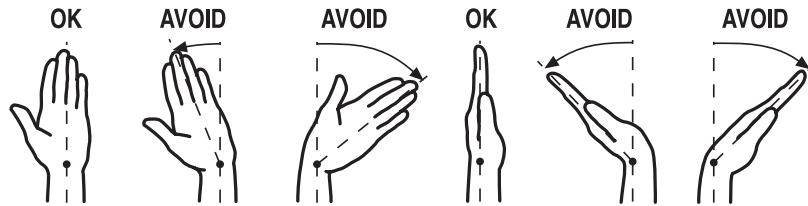

The following suggestions will help reduce or moderate the effects of repetitive work motion and/or extended vibration exposure:

- 1) Do not over-grip the machine/tool. Use only the force required to maintain control.
- 2) Keep hands and body dry and warm. (Blood flow is important - exercise hands and arms as often as necessary.)
- 3) Keep wrists as straight as possible. (Avoid hand positions that require the wrist to be flexed, hyper extended or turned side-to-side.)
- 4) Avoid anything that may inhibit blood circulation such as smoking tobacco or cold temperatures.
- 5) Do not support body-weight on the tool during operation.
- 6) Maintain a stress-free posture for the entire body.

Prolonged exposure to vibrations created by vibrating sources may cause health hazards. There are gloves, handle wraps and other forms of protective measures available to help reduce the hazard. The fit and condition of any vibration abatement measure must be monitored.

Guarding

Always make sure the wheel guard is positioned between the operator and the wheel. Flying debris from the workpiece and/or the wheel can cause a hazard. The guard should be positioned so to deflect debris from the grinding surface away from the operator. The diagram below details the proper positioning of the guard to protect any handles the operator might grip and the area where the operator stands.

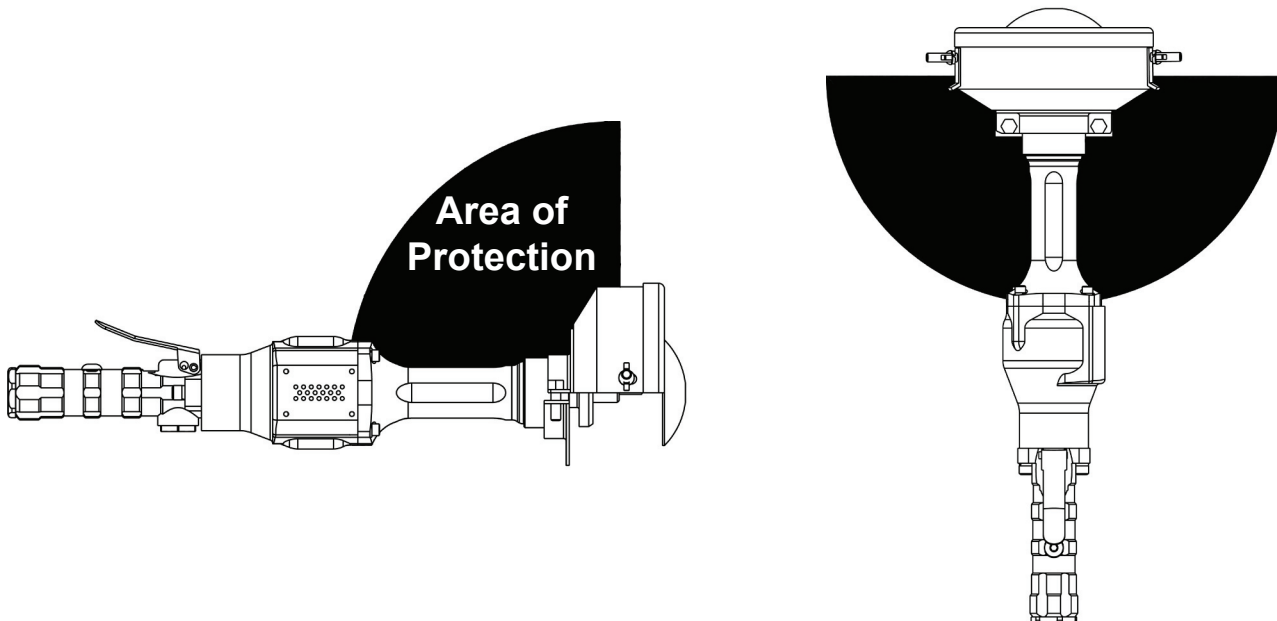

Installation and Maintenance Tips

Following the guidelines will help you to ensure the pneumatic tools your company uses are operating and are maintained in the very best of condition.

Initial Inspection of a New Tool

When a new tool is delivered to your facility, it is important to inspect the tool for any signs of damage that may have occurred during shipping. Here is a list of things to inspect:

- With the tool disconnected from the air supply, depress the throttle lever or trigger. The device should move freely and not become caught.
- Inspect the guard of the tool, if so equipped. The guard should be free of any chips, nicks or dents.
- Inspect the spindle of the tool. The threads should show no signs of bends or chips. Grasp the spindle by hand and spin. The spindle should turn freely with no resistance.

Plumbing Installation

The tool must have fittings and connectors installed into the air inlet in order to connect with your companies air system. Your choice of fittings can greatly affect the performance of the tool.

Fitting Size

The size of the air inlet of the tool is the minimum size of fitting that will allow for proper airflow into the tool. Should a smaller fitting size be used such as reducers or adapters, this will constrict the airflow into the tool and reduce the overall performance.

Coupling Size and Installation

The coupling size should be equal to or larger than the inlet size of the tool. If a smaller size coupling is used then the air supply volume may be reduced which may lead to reduced performance from the tool. The coupling should be installed near to the tool. It is important that the tool receive internal lubrication on a regular basis. Having the connection closer to the tool will promote regular lubrication, as the connection is easily accessible. Hose whips are often used between the tool and the coupling. Use thread sealant on all pipe threads and ensure a tight fit.

Operating Speed Test

After your initial inspection and installation of the plumbing connections, it is important to test for the operating speed of the tool. This test should be performed before you install any abrasive or tooling. Each tool is stamped with a maximum operating speed. This speed determines the highest rotational speed in R.P.M.'s that the tool will turn when it is functioning properly. This speed was set from the factory and is closely related to the operating speed of the abrasive used with the tool. This relationship will be discussed in the "mounting abrasives" section.

Find the maximum operating speed stamped onto the tool. Connect the tool to an air supply that provides 90 psi and secure the tool in a vise. A lower or higher air pressure will result in a false speed test and may create a hazardous situation. Depress the throttle lever or trigger and run the tool. Use a properly calibrated tachometer to determine the actual operating speed of the tool. The actual operating speed on the tachometer should be no greater than 95% of the maximum free speed stamped on the tool. If this is not the case then contact the distributor or tool manufacturer immediately. The tool must not be put into service if the actual speed is over 95% of the stamped maximum speed.

Example:

Tool rated at 6000 R.P.M.

95% of 6000 (.95 x 6000) = 5700

The tool should run no more than 5700 R.P.M. when tested with a tachometer.

Mounting Abrasives

The mounting of the abrasive used with the tool is very important to ensure safety for the operator and proper functioning of the tool. There are strict rules for mounting wheels that are outlined in ANSI B7.1-2000. The following diagrams briefly describe the methods and equipment for mounting most abrasives.

Each wheel/mounted stone is labeled with a maximum operating speed. It is extremely important to compare this rating with the maximum operating speed of the tool. Never mount a wheel on a tool where the maximum operating speed of the tool is higher than the maximum operating speed of the wheel. This can cause an over speed situation and can result in injury.

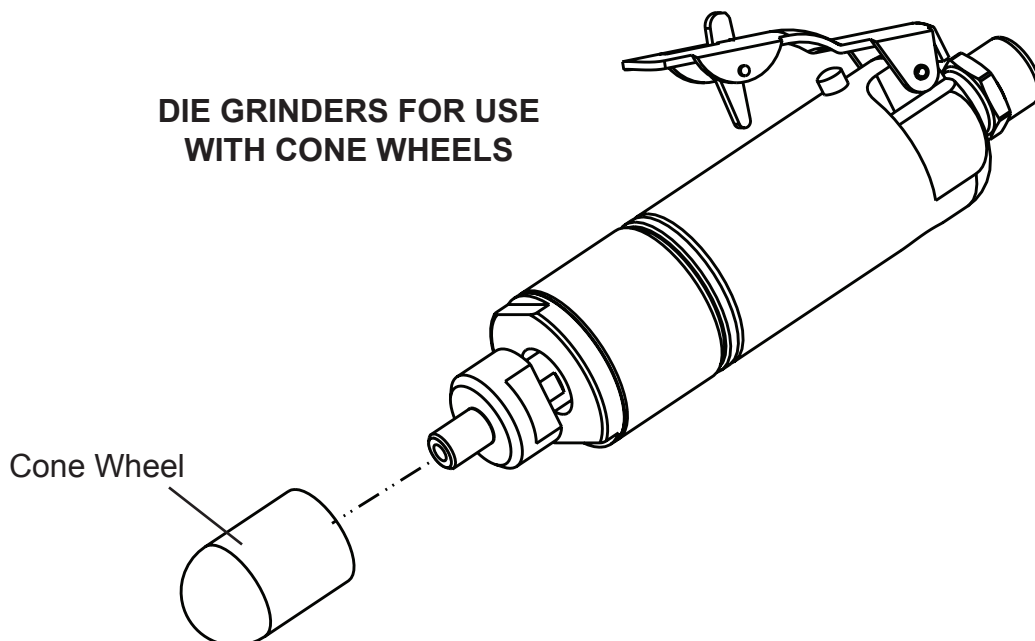
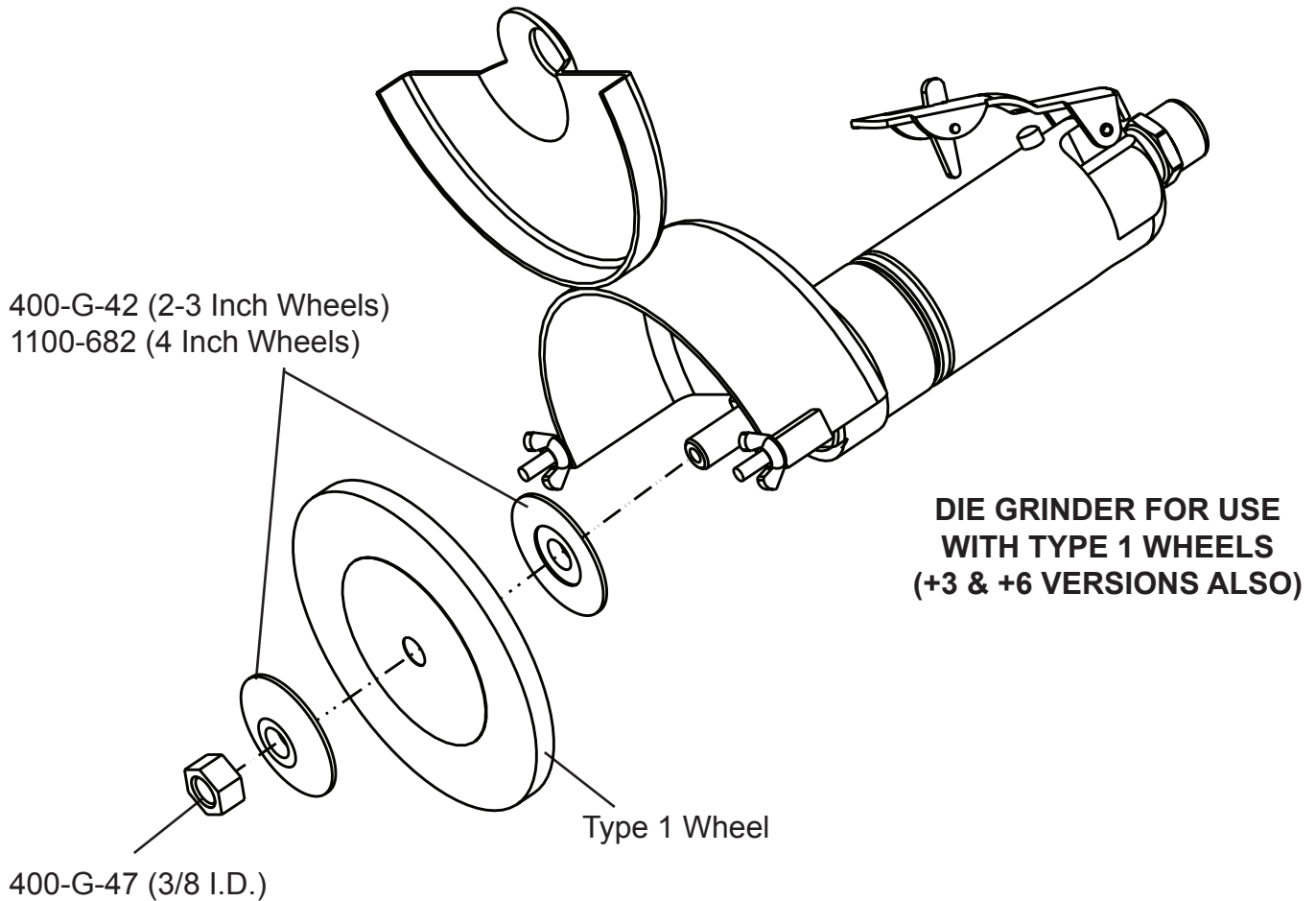

**DIE GRINDER FOR USE
WITH MOUNTED STONES
OR BURRS**

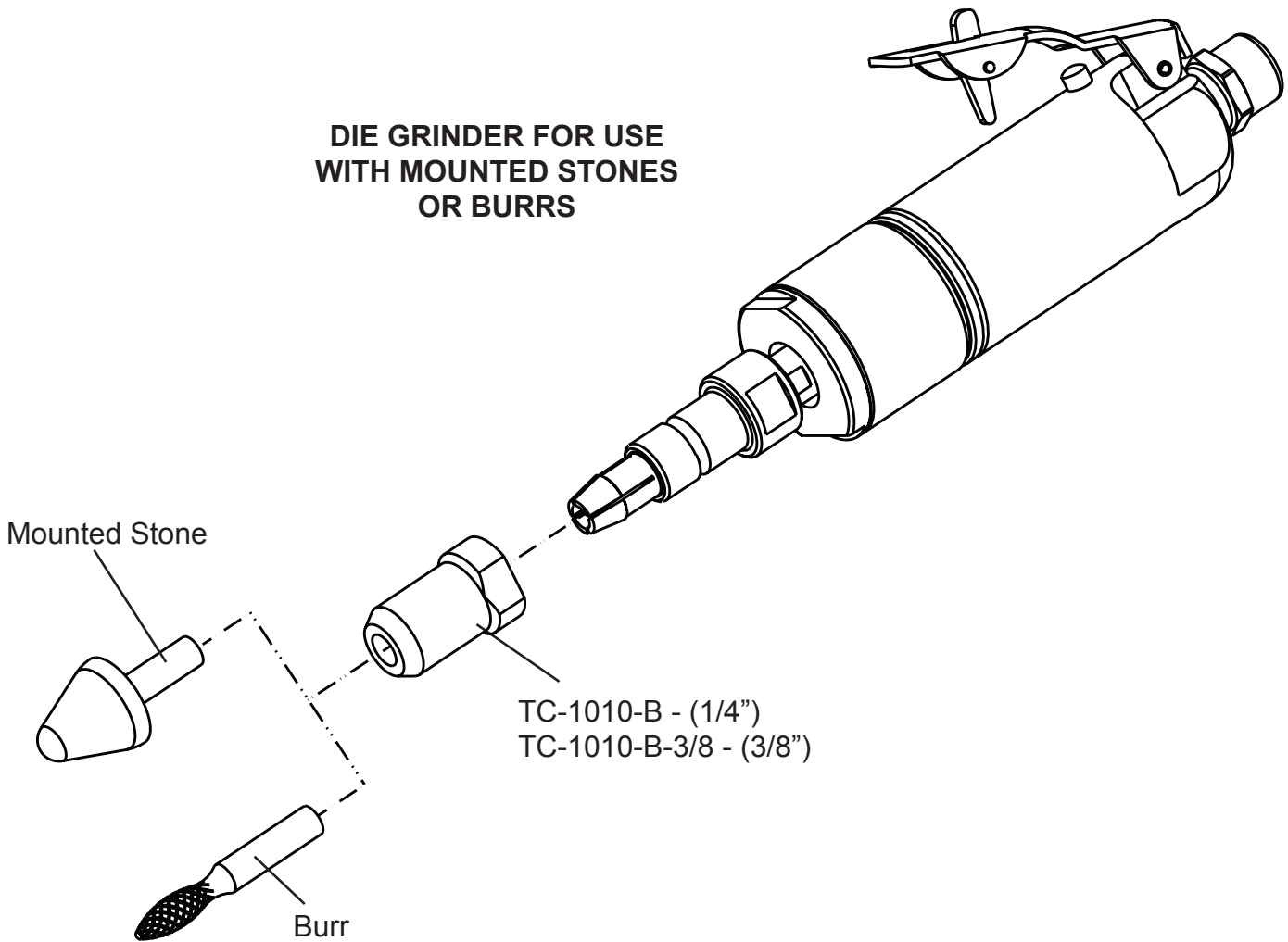

The following list details specific items one should inspect and be aware of when mounting abrasives.

- The maximum operating speed marked on the wheel must be equal to or higher than the rated spindle speed (free speed) of the tool.
- Check the wheel dimensions so that it fits within the guard properly.
- Do not use any wheel that shows cracks, chips or evidence it has been soaked in fluids.
- Wheel flanges should have flat contact surfaces and be without cracks or burrs.

Testing and Mounted Wheel

Start any new grinder with a new wheel under a bench and away from any bystanders. Run at full speed for one minute.

Ensure Proper Pressure, Filtration & Lubrication

Properly lubricated pneumatic tools work better, last longer between maintenance intervals and are safer in general use. The maintenance costs are reduced dramatically when a little time is taken to regularly lubricate the tools. There are several ways to ensure proper lubrication.

1) Filters, Regulators & Lubricators

These devices should be installed in the air system at each grinding station and inspected regularly to ensure proper operation. Each device in this set performs a vital task that greatly affects the performance of the tool and overall longevity of the component parts.

Filters

A filter is a device used to trap/contain particulate and liquid contaminants in the compressed air system. They generally have a cartridge or screen that requires cleaning or replacement regularly. Without this maintenance, the filtering device can become clogged and reduce the flow of air to the tool. A loss in performance can result.

Regulators

A regulator adjusts the operating pressure supplied to the tool. This device generally is used with a pressure gauge that will indicate the current pressure setting. All Top Cat ® pneumatic tools are designed to operate at 90 PSI (6.2 bar) while the tool is running. The tool should never be run if the pressure should exceed 90 PSI (6.2 bar).

Lubricators

Lubricators are devices that induce a controlled amount of oil into the air supply for pneumatically driven tools. They generally contain a reservoir that one must keep filled with oil. A light grade oil such as Mobil DTE light or equivalent is recommended. There is a variable setting on the lubricator that will determine the amount of oil induced into the air supply. It is important to inspect both the setting and amount of oil in the lubricator regularly to determine proper functioning of the device. The lack of oil in the air system will greatly reduce the performance and longevity of the pneumatically driven tool.

2) Direct injection of oil into the tool

A simple and easy way to ensure proper lubrication is to inject the oil directly into the tool air inlet. This should be performed prior to storage of the tool. To perform this task one must have a small container of the proper lubricating oil.

- Disconnect the tool from the air supply at the air coupling.
- Place a few drops of oil from the container into the air inlet of the tool directly.
- Reconnect the tool to the air supply.
- Direct the exhaust of the tool away from any bystanders or cover the exhaust with a shop rag.
- Run the tool until the oil has completely passed through the unit.

The best lubrication techniques include both methods.

What Conditions Indicate the Need for Maintenance?.

Pneumatic tools will exhibit several distinct signs that maintenance is required. Higher costs can be avoided if maintenance is performed when the first signs are evident. The following list details conditions that may indicate the necessity for service.

- 1) With the tool disconnected from the air supply, grasp the spindle and spin in the direction of operation. The spindle should spin freely with no resistance.
- 2) With the tool disconnected from the air supply, grasp the spindle by hand. Attempt to move the spindle from side to side and back and forth. Excess play can be a sign that service is required.
- 3) A reduction in power may indicate the necessity for maintenance.
- 4) Should the tool not maintain a uniform operating speed, servicing may be required.

For More Information

1) General Industry Safety & Health Regulations 29 CFR, Part 1910 and where applicable Construction Industry Safety & Health Regulations 29 CFR, Part 1926 available from Superintendent of Documents, Gov't. Printing Office, Washington, D.C. 20402.

2) Safety Code For Portable Air Tools, ANSI B186.1, B7.1 and Z87.1, available from American National Standards Institute, Inc. 1430 Broadway, New York, NY 10018