

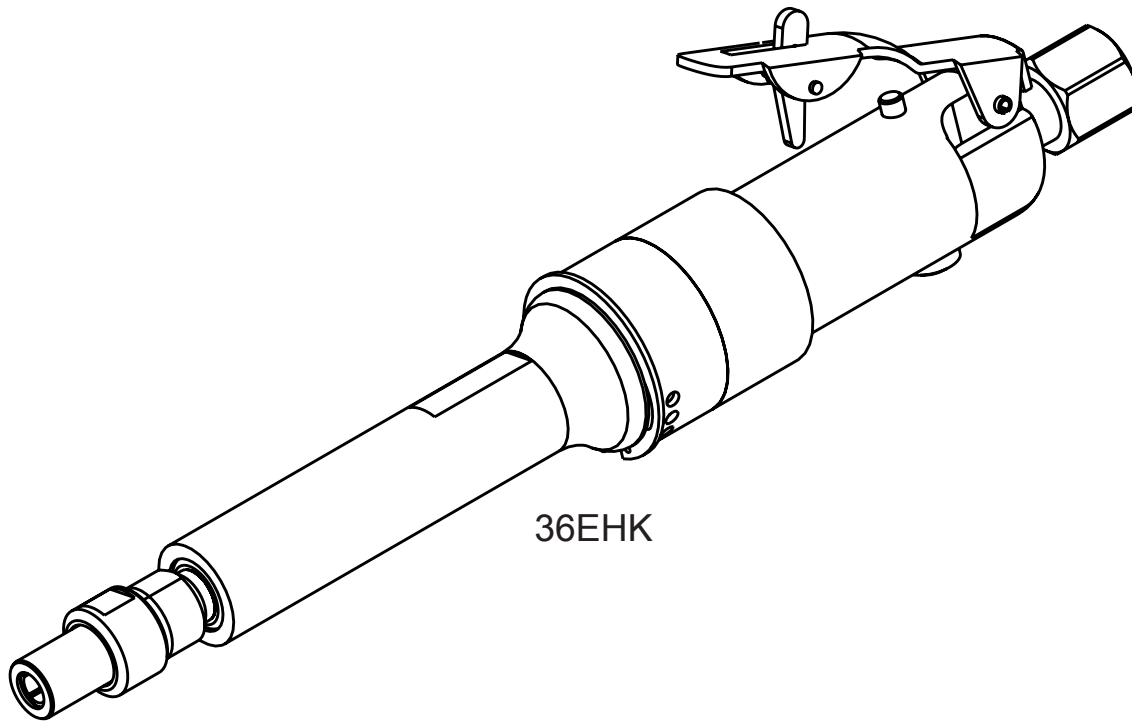

General Operators Instructions and Maintenance Manual

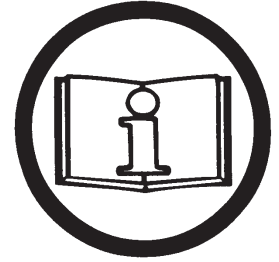

36EHK

Read Safety Recommendations Before Operating Tool

36EH

Model Number	Exhaust Direction	Throttle Type	Rated Speed	Power Output	Case Material	Weight		Overall Length	Diameter	Working Air Consumption	Collet Size
						Aluminum	Steel				
36EH	Side	(L) Lever or (K) Safety Lever	30000 R.P.M.	0.6 H.P. (450 W)	Steel or Aluminum	1.5 lb (0.7 Kg)	1.9 lb (0.9 Kg)	10.5 inch (268 mm)	1.5 inches (38 mm)	20cfm (9.4 L/S)	1/8", 3/16", 1/4", 3mm, 6mm

Capacity*
• Burrs and Mounted Stones

*The use of type 1 or 27 wheels is not within the design of this pneumatic tool.

Top Cat ® Air Tools, Manufactured by T.C. Service Co.

38285 Pelton Road, Willoughby, OH 44094 U.S.A.

Ph: (440) 954-7500 or (800) 321-6876 • Fax: (440) 954-7118 or (877) 800-3589

E-Mail: sales@tcservice.com • Web Site: www.tcservice.com

Operators Instructions and Safety Precautions

This is meant to highlight sections of safety standards published by the American National Standards Institute and the Occupational Safety and Health Administration. This is not meant to replace those standards but only highlight certain areas.

When care is taken to ensure that the right tool is operated properly, and safety and maintenance procedures are followed, accidents can be avoided. Read and follow all instructions and directions. Comply with all rules governing the use of power tools, personal protective equipment and equipment guards.

Remember - machines, attachments and accessories must be used only for the purpose for which they were designed. Safety reasons and product liability prohibit any modifications to tools. Any attachments or accessories must be agreed to in advance with an authorized technical representative of T.C. Service Co.



The grinding equipment must be approved for the rated speed of the machine. The rated speed, marked on the machine, should not be exceeded. Be sure to learn the proper handling and storage of abrasive wheels and inserted tooling.

Inspect the wheel guard for any signs of wear and that it is properly mounted to the tool. Any guard showing signs of wear such as bends, chips, nicks, or cracks should be replaced.



Always wear eye and hearing protection, and when necessary, other personal protective equipment such as gloves, an apron, and helmet. Properly fitted protective clothing cushions the operator from vibration exposure and help prevent minor scrapes that might occur as a result of guiding the tool along the work piece.

Additional information on eye protection is available in the following national regulatory standards.

- 1) Federal OSHA Regulations 29 CFR, Section 1910.133 (Eye and Face Protection)
- 2) ANSI Z87.1 (Occupational and Educational Eye and Face Protection)



Check hose size and air pressure. The air pressure at the tool shall not exceed 90 psi (6.2 bar). All hoses should be inspected regularly and kept away from heat, oil and sharp edges. Be sure the tool is secured to the air hose.

Measure the speed of grinders every 20 hours of actual use or once per week, whichever comes first.

Tachometers must be checked and calibrated on a regular basis according to the manufacturers recommendations

Measure speed of all types of grinders after maintenance or repair, whenever a grinder is issued from the tool crib and at each wheel change. Several readings should be taken.

This form of inspection should be made with the grinding wheel or tooling removed.



Proper mounting of grinding wheels and inserted tooling is crucial to safe operation and efficient working conditions.

Ensure the exhaust air is directed away from bystanders.



Disconnect the tool from the air supply before doing any service. This prevents accidental start-ups.



Airborne particulate resulting from the grinding process can cause hazards. Wear appropriate protective equipment.

Safety in Operation

The safety procedures for operating air tools are everyone's responsibility. The following lists several aspects of air tool safety that should be considered during operation. Please be aware of these aspects and report any unsafe practice you see to a supervisor or safety officer immediately.

- 1) Start any new inserted tooling under a bench and away from bystanders. (Run for a minimum of one minute.)
- 2) When starting a cold/new mounted stone, apply to the work slowly, allowing the mounted stone to warm gradually.
- 3) Support the work piece properly.
- 4) When grinding, support the work piece so that a jamming of the wheel does not occur. (A slot shall remain constant or become wider during operation.)
- 5) If a jamming of the inserted tooling does occur during a grinding operation, shut the air supply off to the tool and ease the mounted stone/burr free. (Inspect the mounted stone/burr for damage before continuing operation.)
- 6) Ensure that sparks from the process do not create a hazard to the eyes or will ignite the environment.
- 7) Grinders shall not be used in potentially explosive atmospheres.
- 8) Pneumatically driven tools are not generally insulated from coming in contact with electrical sources. Be sure to avoid contact with wires or other possible current carrying sources.
- 9) The operator must check that no bystanders are in the vicinity.
- 10) Remember that there is a running on after the throttle has been released.
- 11) If a grinder fitted with a mounted stone/burr is dropped, the mounted stone/burr must be thoroughly examined before re-use.
- 12) Disconnect the tool from the air source before servicing and changing mounted stones/burrs.
- 13) Release the control device in case of interruption of air supply.
- 14) Always keep the tool in a clean, dry place when not in use.
- 15) Beware of loose hair and clothing so as not to become tangled or trapped during operation.
- 16) Unexpected tool movement or breakage of inserted tooling may cause injury
- 17) Unsuitable postures may not allow counteracting of normal or unexpected movement of a power tool. (A working position shall be adopted which remains stable in the event of a break up of tooling.)
- 18) Do not hold the tool near the body when operating.
- 19) Keep a firm grip on the tool body during operation.
- 20) Immediately shut off the tool if unusual vibration or sound is detected. Remove and inspect the wheel and check the tool speed (RPM) with an accurate tachometer. Use of over-speeding grinder or unbalanced wheels may result in serious injury.

Maintenance

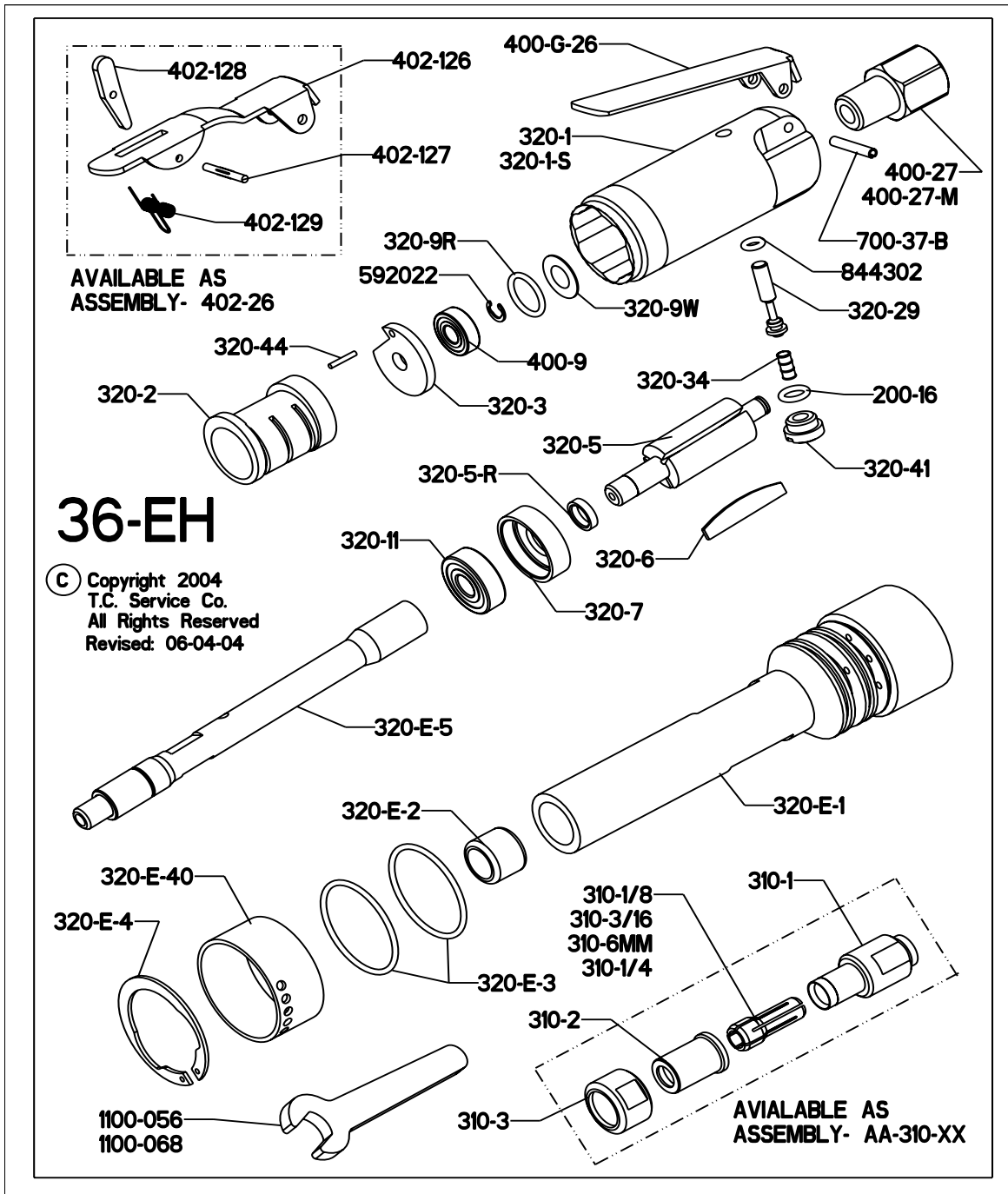

Disassemble

1. Disconnect air and remove all burrs, and accessories.
2. Remove collet nut (310-3), insert retainer (310-2) and insert (310-xx).
3. Secure tool in vise vertically with output of tool oriented upward. Clamp onto the flats toward the rear of the motor housing.
4. Unscrew front housing (320-E-1) from motor housing (320-1[S]) and slide motor out. Remove motor housing from vise.
5. Remove bearing cover (320-9W) and o-ring (320-9R) out of motor housing.
6. Slip retaining ring (592016) from groove of rotor (320-5).
7. Install brass jaws on vise. Secure motor assembly into vise vertically with output oriented in the downward direction. Clamp lightly the outside diameter of the cylinder (320-2) and endplate (320-3).
8. Use a 3/16" punch to tap spindle out of rear bearing (400-9). Be careful not to drop the spindle

assembly when it is free. Remove from vise.

9. Remove 3 blades (320-6).

10. With brass jaws still in vise, firmly clamp rotor in vise with output oriented toward the upward direction. Using a wrench, unscrew the collet body (310-1).

(The spindle can come apart in two places. If the spindle came apart between the collet body and the extension spindle (320-E-5) go to step 11. If the spindle came apart between the extension spindle (320-E-5) and the rotor, go to step 13.

11. Lift off housing (320-E-1).

12. With rotor still clamped in vise, unscrew extension spindle (320-E-5). Remove from vise. Skip to step 14.

13. Pull the spindle assembly forward through the front bearing (320-E-2). Use two wrenches on the flats provided on the collet body and extension spindle to unscrew.

14. Press front bearing (320-E-2) from front housing in an arbor press with bearing driver (1100-828).

15. Support the spindle assembly vertically on a suitable drill block. Press spindle through front bearing (320-11) with an arbor press. Remove spacer (320-5-R).

16. Remove bearing (320-11) from front endplate (320-7) with a small punch.

17. To check throttle valve unscrew throttle valve cap (320-41).

18. Lift out valve spring (320-34) and throttle valve (320-29). Remove and replace o-rings (844302 and 200-16) if cracked or worn.

Assembly

1. Be sure that all parts are clean and free of any abrasive.

2. Install the spacer (320-5-R) onto the threaded end of the rotor. Be sure that the spacer sits flush against the rotor.

3. Press bearing (320-11) into recessed area of front endplate (320-7)

4. Support the front bearing assembly on a suitable drill block. Press the rotor (320-5) into the rear of front endplate and through front bearing with an arbor press.

5. With brass jaws in vise, clamp firmly onto rotor (320-5) with output oriented toward the upward direction. Screw on and tighten extension spindle (320-E-5) onto threaded end of rotor.

6. Use an arbor press to press bearing (320-E-2) into front end of extension housing (320-E-1). Be sure the bearing is flush with the end of the housing. Grease the needle bearing with a lithium soap based, NGLI Grade 2 gear grease.

7. Place the housing over the extension spindle (320-E-5). Screw the collet body onto the threaded end of the spindle and tighten with a wrench. Remove from vise.

8. Place 3 blades (320-6) into rotor slots.

9. Slip cylinder (320-2) over rotor. (be sure the alignment pin is oriented toward the rear of the motor.

10. Install rear endplate (320-3) locating cylinder pin in the small hole of the rear endplate and the cutaway on the side of the endplate over the pocket of the cylinder.

11. Place bearing (400-9) over rear endplate. Tap in place with bearing driver (1100-802).

12. Place snap ring (592016) in spindle groove.

13. Gently grasp front extension housing in brass jaws of vise. Place o-ring (320-9R) and then wafer (320-9W) onto top of rear bearing. Carefully place motor housing (320-1[S]) over motor assembly, taking care that cover and o-ring stay in position on top of bearing. Gently tighten the housing onto the front case. Remove from vise

14. With brass jaws removed from vise, secure tool in vise vertically with output of tool oriented toward the upward direction. Clamp onto the flats toward the rear of the motor housing. Tighten the extension assembly onto motor housing firmly using a wrench.

16. Reinstall all safety devices and accessories.

15. Check the operating speed with a reliable tachometer. The speed must be at or below the stamped speed on the tool.

Tool Parts Listing

<u>PART</u>	<u>DESCRIPTION</u>	<u>TOOLS</u>	<u>DESCRIPTION</u>
200-16	O-RING		
310-3/32	3/32" COLLET INSERT	1100-056	9/16" WRENCH
209-1/8	1/8" COLLET INSERT	1100-068	11/16" WRENCH
209-3/16	3/16" COLLET INSERT	1100-802	400-9 BEARING DRIVER
209-1/4	1/4" COLLET INSERT	1100-828	320-E-2 BEARING DRIVER
209-3MM	3MM COLLET INSERT		
209-6MM	6MM COLLET INSERT		
310-1	4 PIECE COLLET BODY		
310-2	4 PIECE COLLET NOSE PIECE		
310-3	4 PIECE COLLET NUT		
320-E-1	EXTENSION HOUSING		
320-E-2	NEEDLE BEARING		
320-E-3	O-RING (2 REQ.)		
320-E-4	SNAP RING		
320-E-5	EXTENSION SPINDLE		
320-E-40	EXHAUST DEFLECTOR		
320-1	ALUM. CASE (SPECIFY SPEED)		
320-1-S	STEEL CASE (SPECIFY SPEED)		
320-2	CYLINDER		
320-3	REAR ENDPLATE		
320-5	ROTOR		
320-5-R	ROTOR SPACER		
320-6	BLADE (3 REQ)		
320-7	FRONT ENDPLATE		
320-9R	O-RING		
320-9W	BEARING COVER		
320-11	FRONT MOTOR BEARING		
320-29	THROTTLE VALVE-INCLUDES 844302		
320-34	SPRING		
320-41	THROTTLE VALVE CAP		
320-44	CYLINDER PIN		
400-G-26	THROTTLE LEVER		
400-9	REAR BEARING		
400-9A	SEALED REAR BEARING		
400-27	1/4 NPT TO 1/4 NPT BUSHING		
400-27-M	1/4 NPT TO 1/4 BSP BUSHING		
402-126	SAFETY LEVER		
402-127	SAFETY LEVER PIN		
402-128	LOCKOUT LEVER		
402-129	SAFETY LEVER SPRING		
700-37B	THROTTLE LEVER PIN		
592016	SNAP RING		
844302	O-RING		
		<u>ACCESSORIES</u>	
		<u>PART</u>	<u>DESCRIPTION</u>
		530198	1/8" TAPER BURR
		530200	1/8" FLAME BURR
		530202	1/8" BALL BURR
		530204	1/8" CYLINDRICAL BURR
		530208	1/4" BALL BURR
		530210	1/4" CYLINDRICAL BURR
		530212	1/4" TREE BURR
		530214	1/4" FLAME BURR
			OTHER SIZES AVAILABLE
		<u>ASSEMBLIES</u>	
		<u>PART</u>	<u>DESCRIPTION</u>
		510095	REPAIR KIT
		402-26	SAFETY LEVER ASSY.
		AA-320-1	ALUMINUM CASE ASSY.
		AA-320-1-K	ALUMINUM SAFETY CASE ASSY.
		AA-320-1-S	STEEL CASE ASSY.
		AA-320-1-S-K	STEEL SAFETY CASE ASSY.
			SPECIFY SPEED FOR CASE ASSY.
		<u>COLLET ASSEMBLIES</u>	
		<u>PART</u>	<u>DESCRIPTION</u>
		AA-310-3/32	ERICKSON 4 PIECE-3/32" INSERT
		AA-310-1/8	ERICKSON 4 PIECE-1/8" INSERT
		AA-310-3/16	ERICKSON 4 PIECE-3/16" INSERT
		AA-310-1/4	ERICKSON 4 PIECE-1/4" INSERT
		AA-310-3MM	ERICKSON 4 PIECE-3MM INSERT
		AA-310-6MM	ERICKSON 4 PIECE-6MM INSERT
			OTHER SIZES AVAILABLE

Note: Use of any parts other than genuine Top Cat® parts voids any and all warranties, and may result in an unsafe or dangerous situation.

Ergonomics - Work Healthy

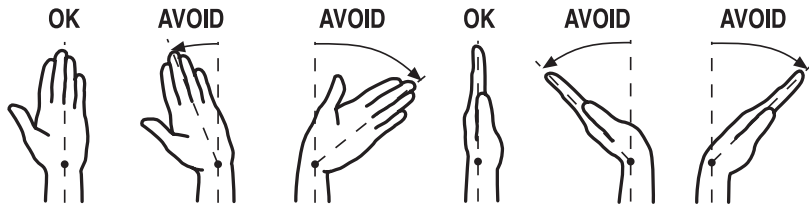

The following suggestions will help reduce or moderate the effects of repetitive work motion and/or extended vibration exposure:

- 1) Do not over-grip the machine/tool. Use only the force required to maintain control.
- 2) Keep hands and body dry and warm. (Blood flow is important - exercise hands and arms as often as necessary.)
- 3) Keep wrists as straight as possible. (Avoid hand positions that require the wrist to be flexed, hyper extended or turned side-to-side.)
- 4) Avoid anything that may inhibit blood circulation such as smoking tobacco or cold temperatures.
- 5) Do not support body-weight on the tool during operation.
- 6) Maintain a stress-free posture for the entire body.

Prolonged exposure to vibrations created by vibrating sources may cause health hazards. There are gloves, handle wraps and other forms of protective measures available to help reduce the hazard. The fit and condition of any vibration abatement measure must be monitored.

Installation and Maintenance Tips

Following the guidelines will help you to ensure the pneumatic tools your company uses are operating and are maintained in the very best of condition.

Initial Inspection of a New Tool

When a new tool is delivered to your facility, it is important to inspect the tool for any signs of damage that may have occurred during shipping. Here is a list of things to inspect:

- With the tool disconnected from the air supply, depress the throttle lever or trigger. The device should move freely and not become caught.
- Inspect the guard of the tool, if so equipped. The guard should be free of any chips, nicks or dents.
- Inspect the spindle of the tool. The threads should show no signs of bends or chips. Grasp the spindle by hand and spin. The spindle should turn freely with no resistance.

Plumbing Installation

The tool must have fittings and connectors installed into the air inlet in order to connect with your company's air system. Your choice of fittings can greatly affect the performance of the tool.

Fitting Size

The size of the air inlet of the tool is the minimum size of fitting that will allow for proper airflow into the tool. Should a smaller fitting size be used such as reducers or adapters, this will constrict the airflow into the tool and reduce the overall performance.

Coupling Size and Installation

The coupling size should be equal to or larger than the inlet size of the tool. If a smaller size coupling is used then the air supply volume may be reduced which may lead to reduced performance from the tool. The coupling should be installed near to the tool. It is important that the tool receive internal lubrication on a regular basis. Having the connection closer to the tool will promote regular lubrication, as the connection is easily accessible. Hose whips are often used between the tool and the coupling. Use thread sealant on all pipe threads and ensure a tight fit.

Operating Speed Test

After your initial inspection and installation of the plumbing connections, it is important to test for the operating speed of the tool. This test should be performed before you install any abrasive or tooling. Each tool is stamped with a maximum operating speed. This speed determines the highest rotational speed in R.P.M.'s that the tool will turn when it is functioning properly. This speed was set from the factory and is closely related to the operating speed of the abrasive used with the tool. This relationship will be discussed in the "mounting abrasives" section.

Find the maximum operating speed stamped onto the tool. Connect the tool to an air supply that provides 90 psi and secure the tool in a vise. A lower or higher air pressure will result in a false speed test and may create a hazardous situation. Depress the throttle lever or trigger and run the tool. Use a properly calibrated tachometer to determine the actual operating speed of the tool. The actual operating speed on the tachometer should be no greater than 95% of the maximum free speed stamped on the tool. If this is not the case then contact the distributor or tool manufacturer immediately. The tool must not be put into service if the actual speed is over 95% of the stamped maximum speed.

Example: Tool rated at 30,000 R.P.M.

$$95\% \text{ of } 30,000 \text{ } (.95 \times 30,000) = 28,500$$

The tool should run no faster than 28,500 R.P.M.'s when tested with a tachometer. Tachometers must be checked and calibrated on a regular basis according to the manufacturers recommendations

Mounting Abrasives

The mounting of the abrasive used with the tool is very important to ensure safety for the operator and proper functioning of the tool. There are strict rules for mounting wheels that are outlined in ANSI B7.1-2000. The following diagrams briefly describe the methods and equipment for mounting most abrasives.

Each wheel/mounted stone is labeled with a maximum operating speed. It is extremely important to compare this rating with the maximum operating speed of the tool. Never mount a wheel on a tool where the maximum operating speed of the tool is higher than the maximum operating speed of the wheel. This can cause an over speed situation and can result in injury.

The following list details specific items one should inspect and be aware of when mounting abrasives.

- The maximum operating speed marked on the wheel or stone must be equal to or higher than the rated spindle speed (free speed) of the tool.
- Do not use any wheel or stone that shows cracks, chips or evidence it has been soaked in fluids.
- Immediately shut off the tool if unusual sound or vibration is detected. Remove and inspect the wheel and check the tool speed (RPM). Use of over-speeding grinder or unbalanced wheels may result in serious injury.

Testing Mounted Stones

Start any new grinder with a new mounted stone under a bench and away from any bystanders. Run at full speed for one minute.

Ensure Proper Pressure, Filtration & Lubrication

Properly lubricated pneumatic tools work better, last longer between maintenance intervals and are safer in general use. The maintenance costs are reduced dramatically when a little time is taken to regularly lubricate the tools. There are several ways to ensure proper lubrication.

1) Filters, Regulators & Lubricators

These devices should be installed in the air system at each grinding station and inspected regularly to ensure proper operation. Each device in this set performs a vital task that greatly affects the performance of the tool and overall longevity of the component parts.

Filters

A filter is a device used to trap/contain particulate and liquid contaminants in the compressed air system. They generally have a cartridge or screen that requires cleaning or replacement regularly. Without this maintenance, the filtering device can become clogged and reduce the flow of air to the tool. A loss in performance can result.

Regulators

A regulator adjusts the operating pressure supplied to the tool. This device generally is used with

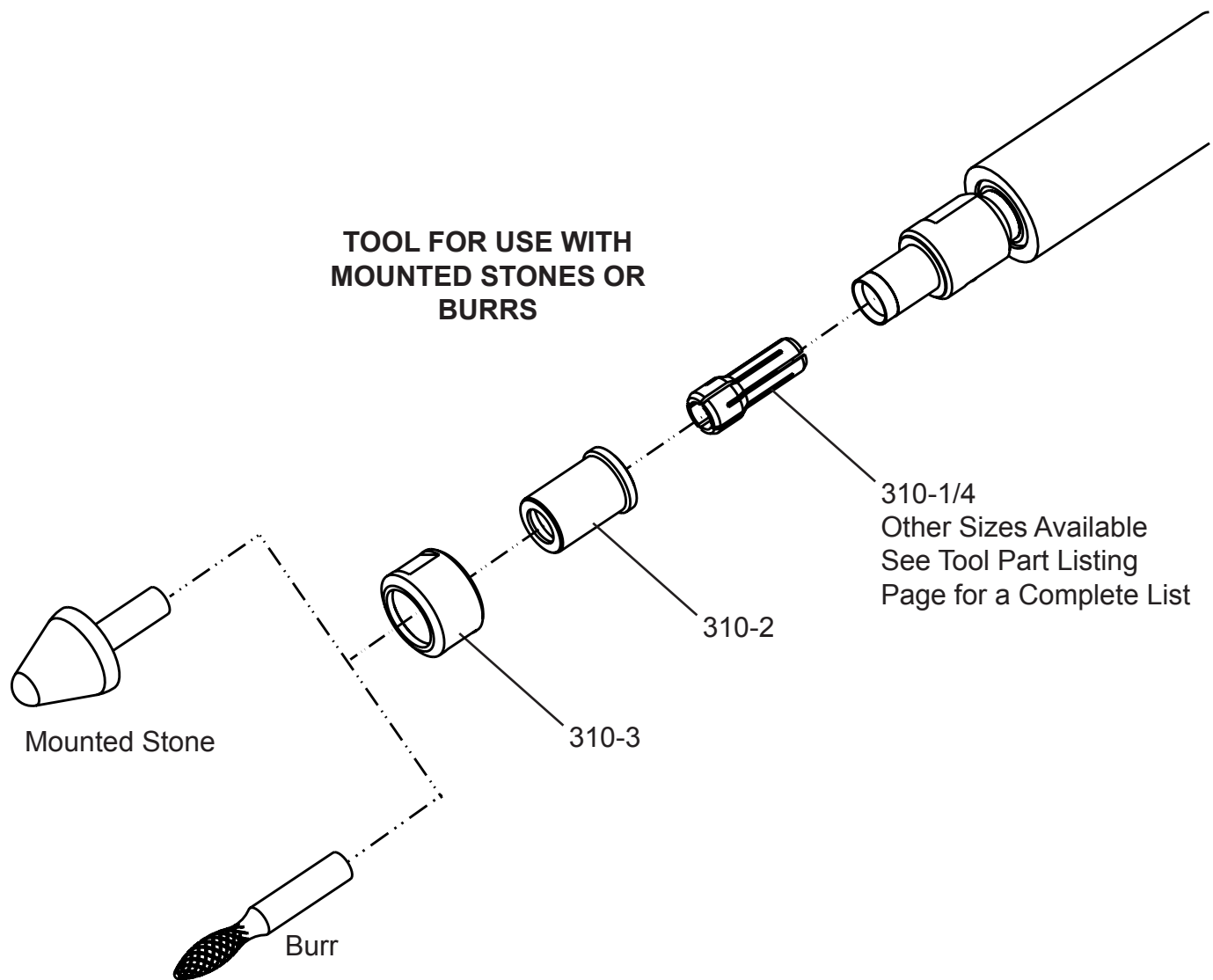

a pressure gauge that will indicate the current pressure setting. All Top Cat ® pneumatic tools are designed to operate at 90 PSI (6.2 bar) while the tool is running. The tool should never be run if the pressure should exceed 90 PSI (6.2 bar).

Lubricators

Lubricators are devices that induce a controlled amount of oil into the air supply for pneumatically driven tools. They generally contain a reservoir that one must keep filled with oil. A light grade oil such as Mobil DTE light or equivalent is recommended. There is a variable setting on the lubricator that will determine the amount of oil induced into the air supply. It is important to inspect both the setting and amount of oil in the lubricator regularly to determine proper functioning of the device. The lack of oil in the air system will greatly reduce the performance and longevity of the pneumatically driven tool.

2) Direct injection of oil into the tool

A simple and easy way to ensure proper lubrication is to inject the oil directly into the tool air inlet. This should be performed prior to storage of the tool. To perform this task one must have a small container of the proper lubricating oil.

- Disconnect the tool from the air supply at the air coupling.
- Place a few drops of oil from the container into the air inlet of the tool directly.
- Reconnect the tool to the air supply.
- Direct the exhaust of the tool away from any bystanders or cover the exhaust with a shop rag.
- Run the tool until the oil has completely passed through the unit.

The best lubrication techniques include both methods.

What Conditions Indicate the Need for Maintenance?.

Pneumatic tools will exhibit several distinct signs that maintenance is required. Higher costs can be avoided if maintenance is performed when the first signs are evident. The following list details conditions that may indicate the necessity for service.

- 1) With the tool disconnected from the air supply, grasp the spindle and spin in the direction of operation. The spindle should spin freely with no resistance.
- 2) With the tool disconnected from the air supply, grasp the spindle by hand. Attempt to move the spindle from side to side and back and forth. Excess play can be a sign that service is required.
- 3) A reduction in power may indicate the necessity for maintenance.
- 4) Should the tool not maintain a uniform operating speed, servicing may be required.

The Common Wear Items:

The Blades (320-6) are subjected to contaminants within the air system. It is common for grit or sand to enter the tool through the air system and become lodged onto the blades. This can cause the blades to delaminate where pieces of blade material will flake off. Any blade exhibiting this characteristic should be replaced. The blades will see the most wear on the longest edge along their height. This is the surface that makes contact with the cylinder wall and creates an air seal. The overall width of the blade will reduce as this surface wears. When any one-end width of the blade wears to the minimum width, (.096 INCH) then one should consider replacement.



The Bearings (320-E-2, 320-11 or 400-9). There is no means of measurement that can determine the condition of a bearing. The only test that can be performed is to manually turn either the outer or inner race with respect to each other. The movement should feel free with no resistance. If resistance is felt either continuous or repetitive, then the bearing should be replaced.

The Front Endplate (320-7). The front endplate is essentially a flat steel disc in the front of the motor assembly. The rotor makes occasional contact with the front endplate. Over time, this contact will wear away the surface of the endplate and result in a circular depression in the middle of the part. When this depression becomes 0.003 inches deep from the original surface, then the efficiency of the motor is reduced to the point where one should replace the endplate.

The Cylinder (320-2). The only wear seen on the cylinder is going to occur on the inner surface. This surface is always in contact with the blades. Over time, the blades will remove material from this surface that will reduce the overall performance of the tool. Consecutive high and low spots will become evident on the internal surface. They will appear as ridges along the axis of the cylinder. When these ridges vary 0.016 inches from high to low, the cylinder should be replaced.

The Rear Endplate (320-3). The rear endplate is located toward the rear of the motor assembly. The most wear this part is exposed to is from occasional contact with the rotor. Over time, this contact will wear away the surface of the endplate and result in a circular depression in the middle of the part. When this depression becomes 0.003 inches deep from the original surface, then the efficiency of the motor is reduced to the point where one should replace the endplate.

This covers all of the predictable wear that can occur within the tool. Other factors due to environment, level of treatment/care and air supply quality can cause other forms of wear that are unpredictable

For More Information

1) General Industry Safety & Health Regulations 29 CFR, Part 1910 and where applicable Construction Industry Safety & Health Regulations 29 CFR, Part 1926 available from Superintendent of Documents, Gov't. Printing Office, Washington, D.C. 20402.

2) Safety Code For Portable Air Tools, ANSI B186.1, B7.1 and Z87.1, available from American National Standards Institute, Inc. 1430 Broadway, New York, NY 10018



Grinders

- Vertical Grinders
- Horizontal Grinders
- Right Angle Grinders
- Die Grinders
- Extended Grinders
- Bench Grinders

Polishers

- Vertical Polishers
- Horizontal Polishers
- Right Angle Polishers

Percussion Tools

- Scalers
- Needle Scalers
- Chipping Hammers
- Rammers

Saws

Air Motors

Drills



T.C. Service Co.
38285 Pelton Rd.
Willoughby, OH 44094
U.S.A.
Ph: 440-954-7500
Fax: 440-954-7118

© Copyright 2004
All Rights Reserved