

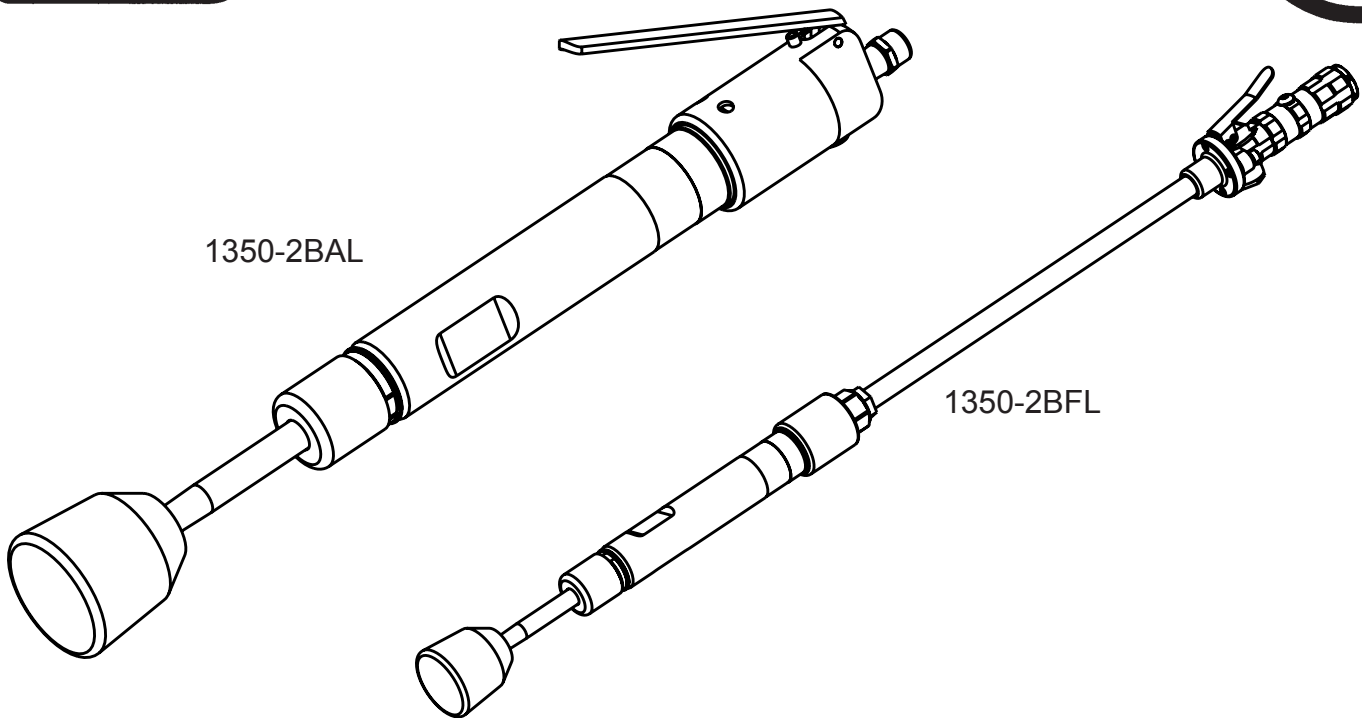

General Operators Instructions and Maintenance Manual

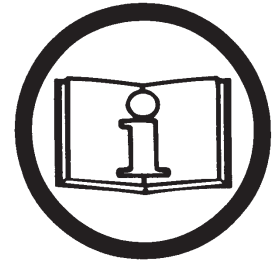

1350-2BAL

1350-2BFL

Read Safety Recommendations Before Operating Tool

1350-2BA / 1350-2BF Rammers							
Model Number	Throttle Type	Bore and Stroke	Blows per Minute	Weight	Overall Length	Body Diameter	Working Air Consumption
1350-2BA	(L) Lever or (K) Safety Lever	1.0 Inch x 4.0 Inch (25 mm x 102 mm)	1240	10.7 Lb. (4.8 Kg.)	22.2 Inches (564 mm)	1.88 Inches (48 mm)	20 cfm (9.4 L/S)
1350-2BF				14.3 Lb. (6.5 Kg.)	36.2 Inches (921 mm)		

Top Cat ® Air Tools, Manufactured by T.C. Service Co.

38285 Pelton Road, Willoughby, OH 44094 U.S.A.

Ph: (440) 954-7500 or (800) 321-6876 • Fax: (440) 954-7118 or (877) 800-3589

E-Mail: sales@tcservice.com • Web Site: www.tcservice.com

Operators Instructions and Safety Precautions

This is meant to highlight sections of safety standards published by the American National Standards Institute and the Occupational Safety and Health Administration. This is not meant to replace those standards but only highlight certain areas.

When care is taken to ensure that the right tool is operated properly, and safety and maintenance procedures are followed, accidents can be avoided. Read and follow all instructions and directions. Comply with all rules governing the use of power tools, personal protective equipment and equipment guards.

Remember - machines, attachments and accessories must be used only for the purpose for which they were designed. Safety reasons and product liability prohibit any modifications to tools. Any attachments or accessories must be agreed to in advance with an authorized technical representative of T.C. Service Co.



Disconnect the tool from the air supply before doing any service. This prevents accidental start-ups.

Never start the tool with the butt or pein pointed at yourself or another person.



Airborne particulate resulting from the compaction and compression process can cause hazards. Wear appropriate protective equipment.

Check hose size and air pressure. The air pressure at the tool shall not exceed 90 psi (6.2 bar). All hoses should be inspected regularly and kept away from heat, oil and sharp edges. Be sure the tool is secured to the air hose.

Proper mounting of butts and piens or other tooling is crucial to safe operation and efficient working conditions. Ensure the exhaust air is directed away from bystanders.



Always wear eye and hearing protection, and when necessary, other personal protective equipment such as gloves, an apron, and helmet. Properly fitted protective clothing cushion the operator from vibration exposure and help prevent minor scrapes that might occur as a result of guiding the tool along the work piece.

Additional information on eye protection is available in the following national regulatory standards.
1) Federal OSHA Regulations 29 CFR, Section 1910.133 (Eye and Face Protection)
2) ANSI Z87.1 (Occupational and Educational Eye and Face Protection)

Safety in Operation

The safety procedures for operating air tools are everyone's responsibility. The following lists several aspects of air tool safety that should be considered during operation. Please be aware of these aspects and report any unsafe practice you see to a supervisor or safety officer immediately.

- 1) The butt, pein or other tooling on heavy types of percussive, non-rotary power tools is exposed to heavy strains and can, after long period of use, break due to fatigue.
- 2) Unexpected tool movement or breakage of tool may cause injury.
- 3) Unsuitable postures may not allow counteracting of normal or unexpected movement of the power tool. (A working position shall be adopted which remains stable in the event of a break up of the tool.)
- 4) Support the work piece properly.
- 5) Holding the moving piston by the free hand can be a source of vibration damage.
- 6) If the tool jams, shut off the power and ease the butt, pein or other tooling free. (Check the butt, pein or other tooling for damage before continuing operation.)
- 7) Ensure that sparks from the process do not create a hazard to eyes or will ignite the environment.
- 8) Percussive tools shall not be used in potentially explosive atmospheres.
- 9) Pneumatically driven tools are not generally insulated from coming into contact with electric sources. Be sure to avoid contact with wires or other possible current carrying sources.
- 10) The operator must check that no bystanders are in the vicinity.
- 11) Disconnect the power supply before servicing and changing of tooling.
- 12) Release control device in case of interruption of energy supply.
- 13) Always keep the tool in a clean, dry place when not in use.
- 14) Do not hold tool near body when operating.
- 15) Keep a firm grip on tool during operation.
- 16) Do not ram toward your body.
- 17) If a quick disconnect hose fitting is used, insert a whip hose between coupling and the tool.
- 18) Never carry a tool by the hose.
- 19) Never yank the hose to disconnect it from the air supply.
- 20) Keep hoses away from heat, oil, sharp edges and in good repair. Inspect hoses regularly.
- 21) Check to see that tool is securely fastened to air hose.
- 22) In air hoses larger than ½ inch, a safety excess flow valve must be installed at the source of the air supply to reduce pressure in case of hose failure.
- 23) Before operating the tool, see that the butt, pein or other tooling is properly and securely installed. Prevent attachments such as butt, pein or other implements from being ejected from the tool when operated.
- 24) Never leave a tool attached to supplied air unattended. Avoid accidental actuation.
- 25) Always disconnect the tool from the air supply or shut off and drain the air hose prior to changing butts, peins, or other tooling.
- 26) Never point or direct a tool toward another worker or yourself.
- 27) When working in close proximity to other workers, suitable barriers may need to be erected around work areas to protect workers from possible tool ejections or flying pieces from the ramming or compacting process itself.
- 28) Be sure to wear the properly fitted personal protective equipment required to guard against operator injury.
- 29) Immediately shut off the tool if unusual vibration or sound is detected. Inspect pistons, butts, peins, or other tooling and entire tool to determine cause of problem, and repair properly before returning tool to service.

Maintenance

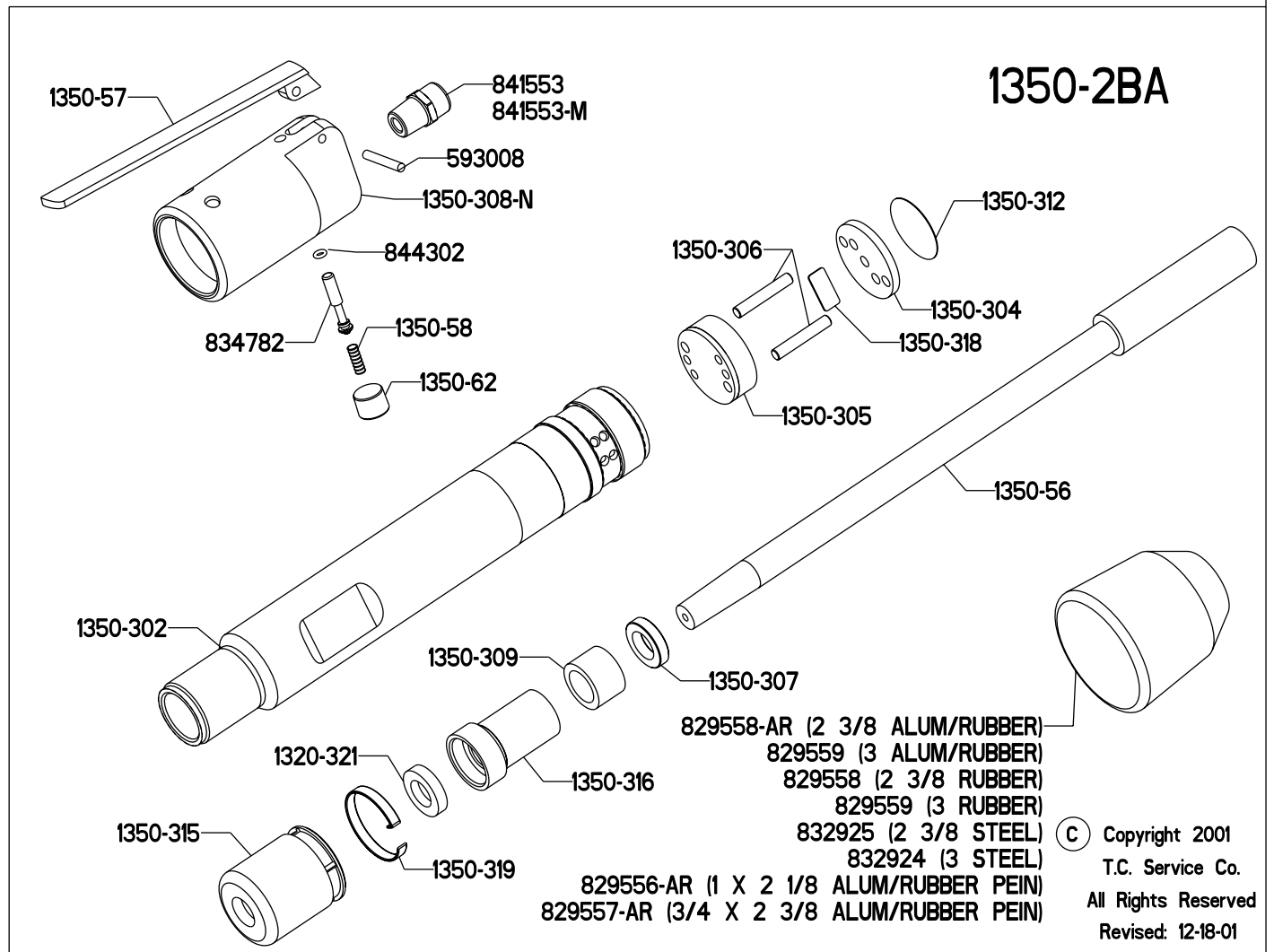

Disassembly

1. Disconnect air supply and remove all accessories, butts, and peins.
2. On model 1350-2BFA, unscrew tool from extension pipe.
2. Position tool in vise vertically with output of tool upward. Clamp onto the sides of backhead (1350-308A or 1350-320).
3. Use a small screwdriver to lift the tab on clip (1350-319) out of the slot on the packing nut (1350-315). Lift and move the clip so that the tab is fully disengaged from the packing nut.
4. Remove packing nut from barrel (1350-302).
5. Grasp piston (1350-56) firmly and remove from tool. Remove packing gland (1350-316), packing (1350-309), and packing washer (1350-307) from piston. Remove from vise.
6. Clamp tool in vise with output of the tool oriented downward. Clamp onto the flats on the side of the barrel (1350-302). Unscrew and remove the backhead assembly.
7. Lift off the main valve assembly, including the screen (1350-312), the upper valve block (1350-304), the lower valve block (1350-305) and the pins (1350-306). Remove from vise.
8. Turn the lower valve block over to remove the valve (1350-318)
9. Remove seal (1350-321) from the packing gland (1350-316) using a small punch if the seal needs replacement.
10. To check throttle valve on 1320-2BA, remove cap (1350-62) using an Allen® wrench. Lift

out throttle valve spring (400-G-34) and throttle valve (834782). Replace o-ring (844302) if cracked or torn.

11. To check throttle valve on 1320-2BF, unscrew throttle valve cap (700-S-26). Lift out valve spring (600-51) and throttle valve (560-13). Replace o-ring (200-9) if cracked or torn.

Assembly

1. Be sure all parts are clean and free of any abrasive.
2. Clamp the barrel assembly in the vise vertically with the front of tool oriented downward. Clamp onto the flats on the front of the barrel (1350-302).
3. Place the dowel pins (1350-306) into the blind holes of the barrel. The blind holes are those that you can see the bottoms of.
4. Place the lower valve block (1350-305) onto the pins. (Be sure not to block the ports.) The lower valve block assembles with the center valve slot facing the rear of the tool.
5. Drop a valve (1350-318) into slot in the lower valve block. Apply a few drops of light oil to the valve.
6. Slide upper valve block (1350-304) over pins. (Be sure to align the port holes.)
7. Place the screen (1350-312) on the center of the upper valve block.
9. Screw on backhead assembly by hand. Tighten with use of a wrench. Remove from vise.
10. Clamp the tool in a vise vertically with the front of tool toward the upward direction. Clamp onto the flats of the backhead.
11. Press seal (1350-321) into packing gland (1350-316) if it was removed.
12. Grasp piston (1350-56) by the large end. Slide on the packing washer (1350-307) with the chamfer towards the large end of the piston.
13. Slide the packing (1350-309) onto the piston.
14. Slide the packing gland (1350-316) onto the piston with the seal towards the tapered end of the piston.
15. Place the piston assembly into the front of the barrel. The larger end should be oriented toward the back of the tool. It should slide freely. Push the packing washer, packing and packing gland into the nose of the barrel. The packing gland will not go all of the way into the barrel.
16. Screw on the packing gland nut until it is tight, then loosen a half turn.
17. Hook the tool up to the air supply and place back into vise with the output oriented upward. Clamp securely onto the flats on the backhead.
18. Taking care that no one is near the moving piston, apply air in a few short burst. If the piston is not moving freely, loosen the locknut another half turn. If the piston is still not moving freely, take the tool back apart and check for burrs or other damage.
19. If the piston is moving freely, re-apply the air to the tool, and carefully tighten the packing gland nut until the piston just begins to slow down, then back off the packing gland nut until one of the notches on the rear of the gland nut aligns with the slot on the front of the barrel.
20. Using 2 needle nose pliers, fit clip (1350-319) onto the groove of the packing nut (1350-315) placing the tab end of the key into the slot on the packing nut that is over the slot. The tab of the clip must engage the slot on the barrel fully, so the gland nut cannot turn.
21. Reinstall butt or pein tightly onto the piston. Reinstall all safety devices and accessories.
- 22. Run tool for a full minute away from yourself or anyone else to insure the butt or pein is firmly attached and the tool is functioning properly.**

Tool Parts Listing

PART	DESCRIPTION
402-127	SAFETY LEVER PIN
402-128	LOCKOUT LEVER
402-129	SAFETY LEVER SPRING
650-34	SCREEN
1100-326	LIVE HANDLE TO 1/2" NPT ADAPTER
1350-56	PISTON
1350-57	LEVER
1350-57-K	SAFETY LEVER
1350-58	SPRING
1350-62	THROTTLE VALVE PLUG
1350-302	BARREL
1350-304	UPPER VALVE BLOCK
1350-305	LOWER VALVE BLOCK
1350-306	VALVE BLOCK DOWEL PIN (2 REQ.)
1350-307	PACKING GLAND WASHER
1350-308A	LEVER BACKHEAD
1350-309	PACKING
1350-312	SCREEN
1350-315	PACKING NUT
1350-316	PACKING GLAND
1350-318	MAIN VALVE
1350-319	CLIP
1350-320	BACKHEAD FOR EXTENSION
1350-321	SEAL
1350-324	EXTENSION PIPE
593008	THROTTLE LEVER PIN
834782	THROTTLE VALVE-INCLUDES 844302

PART	DESCRIPTION
841552	3/8 NPT TO 3/8 NPT BUSHING
841553	3/8 NPT TO 1/4 NPT BUSHING
841553-M	3/8 NPT TO 3/8 BSP BUSHING
844302	O-RING

ASSEMBLIES

PART	DESCRIPTION
AA-1350-68	COMPLETE LEVER BACKHEAD ASSY.
AA-1350-68-K	COMP. SAFETY LEVER BACKHEAD ASSY.

BUTTS & PEINS

PART	DESCRIPTION
829554	1-3/4" DIAMETER RUBBER BUTT
829556	1" X 2-7/8" RUBBER PEIN
829556-AR	1" X 2-7/8" ALUMINUM/RUBBER PEIN
829557	3/4" X 2-3/8" RUBBER PEIN
829557-AR	3/4" X 2-3/8" ALUMINUM/RUBBER PEIN
829558	2-3/8" DIAMETER RUBBER BUTT
829558-AR	2-3/8" DIAMETER ALUMINUM/RUBBER BUTT
829559	3" DIAMETER RUBBER BUTT
829559-AR	3" DIAMETER ALUMINUM/RUBBER BUTT
829560-4R	4" DIAMETER RUBBER BUTT
829560-4S	4" DIAMETER STEEL BUTT
832924	3" DIAMETER STEEL BUTT
832925	2-1/2" DIAMETER STEEL BUTT
832925-HD	2-1/2" DIAMETER HEAVY DUTY STEEL BUTT
	OTHER SIZES & STYLES AVAILABLE

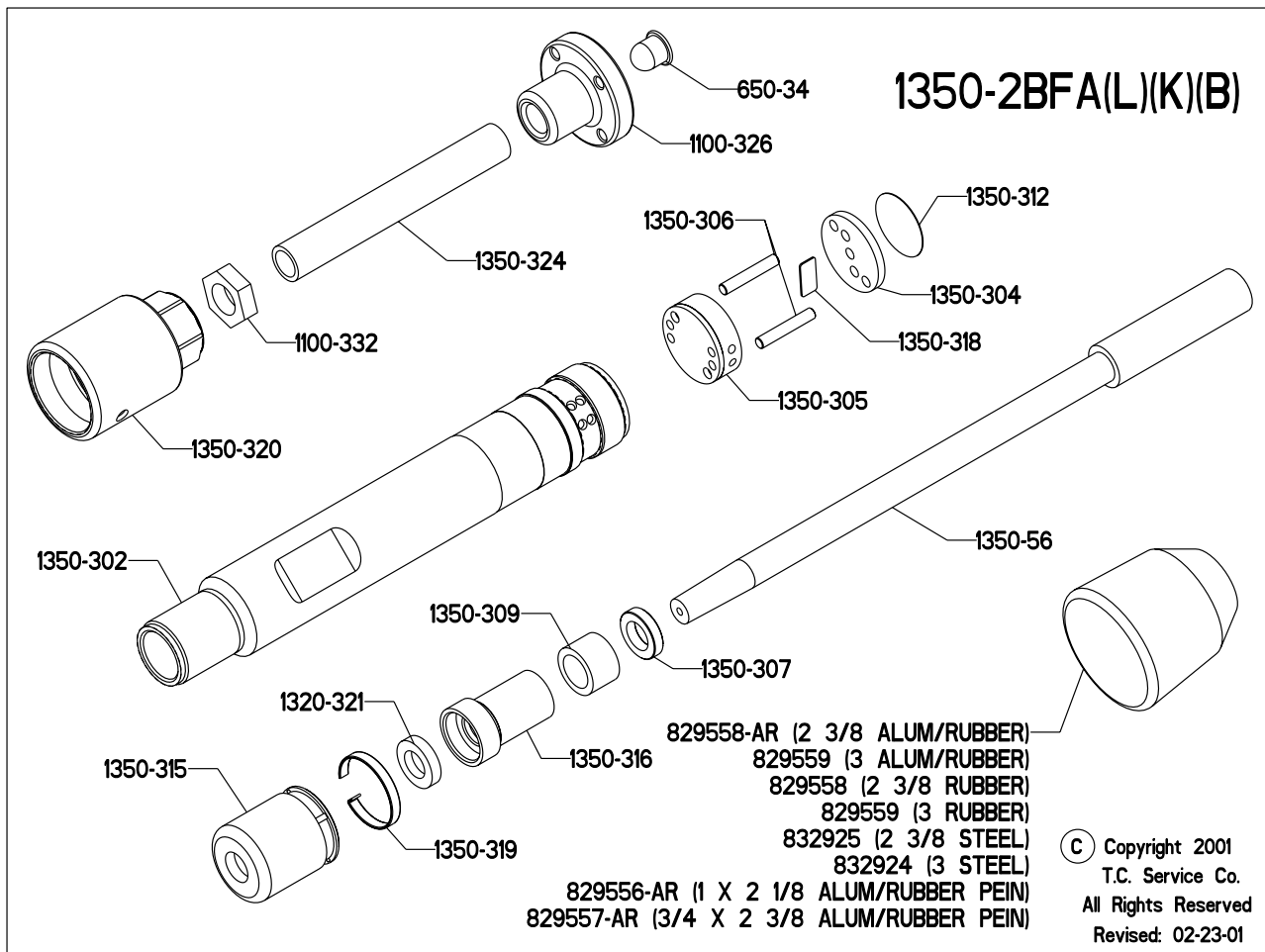

Live Handle Parts Listing

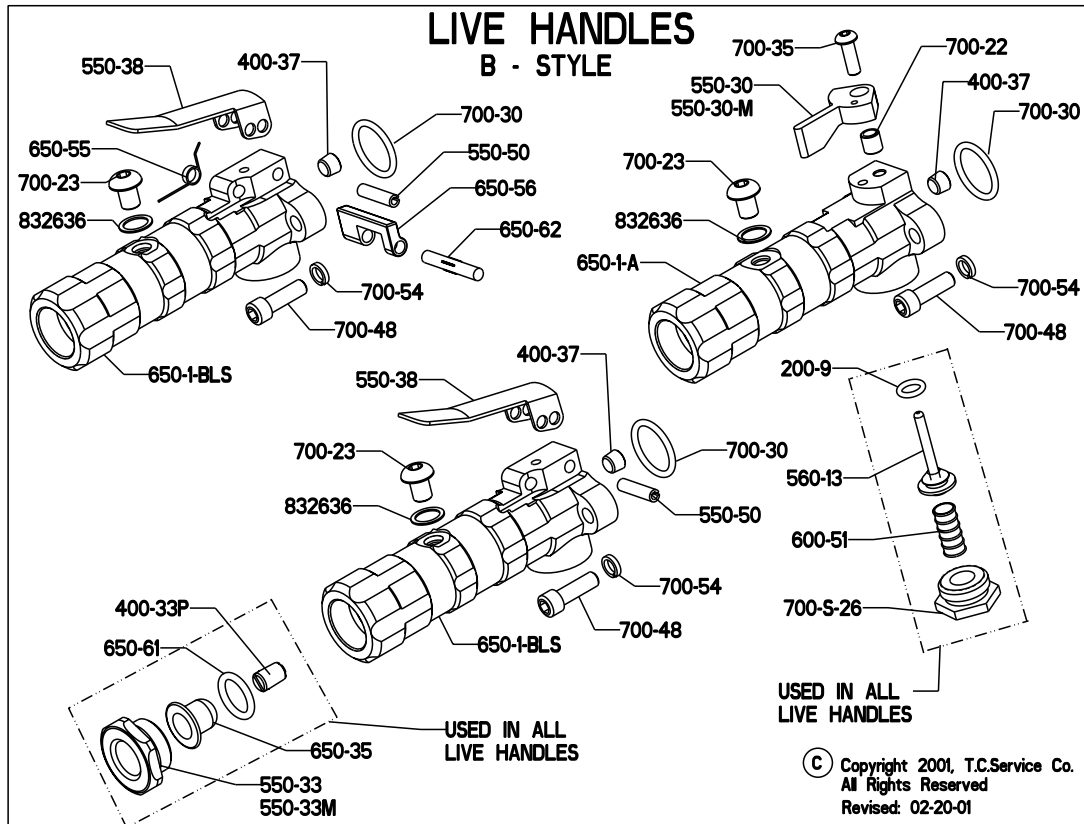

Note: Use of any parts other than genuine Top Cat® parts voids any and all warranties, and may result in a hazardous situation and a decrease in operating efficiency.

PART NUMBER

DESCRIPTION

200-9	THROTTLE VALVE O-RING
400-33P	OILER PLUG
400-37	SET SCREW
550-30	OPERATING BUTTON
550-30M	MACHINE MOUNT BUTTON
550-33	ADAPTER CAP
550-33M	METRIC ADAPTER CAP
550-38	LEVER
550-50	LEVER PIN
560-13	THROTTLE VALVE ASSY (INCLUDES 200-9)
600-51	THROTTLE VALVE SPRING
650-1A	BARE BUTTON HANDLE
650-1AT	BARE TURNED DOWN BUTTON HANDLE
650-1B-KN	BARE KNURLED BUTTON HANDLE
650-1-BLS	BARE LEVER HANDLE
650-1-BLS-KN	BARE KNURLED SAFETY HANDLE
650-1-U	BARE PINNED LEVER HANDLE
650-35	SCREEN BASKET
650-55	SAFETY LOCKOUT SPRING
650-56	LOCKOUT
650-61	O-RING
650-62	SAFETY LEVER LOCKOUT PIN
700-22	SPACER FOR BUTTON HANDLES
700-23	OILER PLUG SCREW
700-30	O-RING
700-35	BUTTON HANDLE SCREW
700-48	SCREW (2 REQ.)
700-54	LOCK WASHER (2 REQ.)
700-S-26	THROTTLE VALVE CAP
832636	GASKET

HANDLE ASSEMBLIES

PART NUMBER	DESCRIPTION
AA-650-1A	BUTTON HANDLE ASSY.
AA-650-1-AM	MACHINE MOUNT HANDLE ASSY.
AA-650-1-BL	LEVER HANDLE ASSY.
AA-650-1-BLS	SAFETY HANDLE ASSY.
AA-650-1-BL-KN	KNURLED LEVER HANDLE ASSY.
AA-650-1-BL-KN-W	KNURLED LEVER HANDLE ASSY. W/ WRAP
AA-650-1-UK	PINNED/SAFETY LEVER HANDLE ASSY
AA-650-1-UL	PINNED LEVER HANDLE ASSY

Ergonomics - Work Healthy

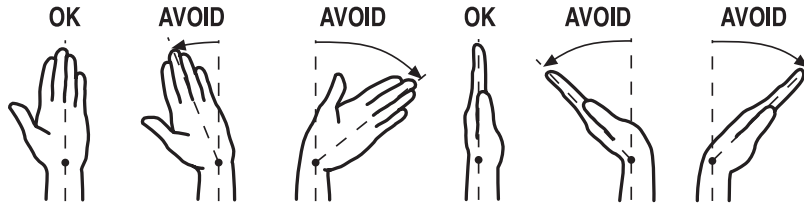

The following suggestions will help reduce or moderate the effects of repetitive work motion and/or extended vibration exposure:

- 1) Do not over-grip the machine/tool. Use only the force required to maintain control.
- 2) Keep hands and body dry and warm. (Blood flow is important - exercise hands and arms as often as necessary.)
- 3) Keep wrists as straight as possible. (Avoid hand positions that require the wrist to be flexed, hyper extended or turned side-to-side.)
- 4) Avoid anything that may inhibit blood circulation such as smoking tobacco or cold temperatures.
- 5) Do not support body-weight on the tool during operation.
- 6) Maintain a stress-free posture for the entire body.

Prolonged exposure to vibrations created by vibrating sources may cause health hazards. There are gloves, handle wraps and other forms of protective measures available to help reduce the hazard. The fit and condition of any vibration abatement measure must be monitored.

Installation and Maintenance Tips

Following the guidelines will help you to ensure the pneumatic tools your company uses are operating and are maintained in the very best of condition.

Initial Inspection of a New Tool

When a new tool is delivered to your facility, it is important to inspect the tool for any signs of damage that may have occurred during shipping. Here is a list of things to inspect:

- With the tool disconnected from the air supply, depress the throttle lever or trigger. The device should move freely and not become caught.
- Inspect the fit of the butt or pein onto the tool. The tooling should fit properly onto the front of the tool. The piston should move freely with butt or pein installed.

Plumbing Installation

The tool must have fittings and connectors installed into the air inlet in order to connect with your company's air system. Your choice of fittings can greatly affect the performance of the tool.

Fitting Size

The size of the air inlet of the tool is the minimum size of fitting that will allow for proper airflow into the tool. Should a smaller fitting size be used such as reducers or adapters, this will constrict the airflow into the tool and reduce the overall performance.

Coupling Size and Installation

The coupling size should be equal to or larger than the inlet size of the tool. If a smaller size coupling is used then the air supply volume may be reduced which may lead to reduced performance from the tool.

The coupling should be installed near to the tool. It is important that the tool receive internal lubrication on a regular basis. Having the connection closer to the tool will promote regular lubrication, as the connection is easily accessible. Hose whips are often used between the tool and the coupling.

Use thread sealant on all pipe threads and ensure a tight fit.

Operation Test

After your initial inspection and installation of the plumbing connections, it is important to test for proper operation. Support the butt or pein of the tool against a test plate and turn on the tool. The tool should begin a regular series of impacts. Run for a short time to ensure proper operation. Immediately shut off the tool if unusual sound or vibration is detected. Remove and inspect the butt or pein and the entire tool. Use of improperly functioning rammers or damaged tooling may result in serious injury.

Ensure Proper Pressure, Filtration & Lubrication

Properly lubricated pneumatic tools work better, last longer between maintenance intervals and are safer in general use. The maintenance costs are reduced dramatically when a little time is taken to regularly lubricate the tools. There are several ways to ensure proper lubrication.

1) Filters, Regulators & Lubricators

These devices should be installed in the air system at each work station and inspected regularly to ensure proper operation. Each device in this set performs a vital task that greatly affects the performance of the tool and overall longevity of the component parts.

Filters

A filter is a device used to trap/contain particulate and liquid contaminants in the compressed air system. They generally have a cartridge or screen that requires cleaning or replacement regularly. Without this maintenance, the filtering device can become clogged and reduce the flow of air to the tool. A loss in performance can result.

Regulators

A regulator adjusts the operating pressure supplied to the tool. This device generally is used with a pressure gauge that will indicate the current pressure setting. All Top Cat® pneumatic tools are designed to operate at 90 PSI (6.2 bar) while the tool is running. The tool should never be run if the pressure should exceed 90 PSI (6.2 bar).

Lubricators

Lubricators are devices that induce a controlled amount of oil into the air supply for pneumatically driven tools. They generally contain a reservoir that one must keep filled with oil. A light grade oil such as Mobil DTE light or equivalent is recommended. There is a variable setting on the lubricator that will determine the amount of oil induced into the air supply. It is important to inspect both the setting and amount of oil in the lubricator regularly to determine proper functioning of the device. The lack of oil in the air system will greatly reduce the performance and longevity of the pneumatically driven tool.

2) Direct injection of oil into the tool

A simple and easy way to ensure proper lubrication is to inject the oil directly into the tool air inlet. This should be performed prior to storage of the tool. To perform this task one must have a small container of the proper lubricating oil.

- Disconnect the tool from the air supply at the air coupling.
- Place a few drops of oil from the container into the air inlet of the tool directly.
- Reconnect the tool to the air supply.
- Direct the exhaust of the tool away from any bystanders or cover the exhaust with a shop rag.
- Run the tool until the oil has completely passed through the unit.

The best lubrication techniques include both methods.

What Conditions Indicate the Need for Maintenance?

Pneumatic tools will exhibit several distinct signs that maintenance is required. Higher costs can be avoided if maintenance is performed when the first signs are evident. The following list details conditions that may indicate the necessity for service.

- 1) A reduction in power may indicate the necessity for maintenance.
- 2) Should the tool not maintain a uniform operating frequency, servicing may be required.

The most common wear item is the piston. Measure the large end of the piston at the center and each end. When this difference becomes 0.002 inches or more, then the efficiency of the rammer is reduced to the point where one should replace the piston.

For More Information

1) General Industry Safety & Health Regulations 29 CFR, Part 1910 and where applicable Construction Industry Safety & Health Regulations 29 CFR, Part 1926 available from Superintendent of Documents, Gov't. Printing Office, Washington, D.C. 20402.

2) Safety Code For Portable Air Tools, ANSI B186.1, B7.1 and Z87.1, available from American National Standards Institute, Inc. 1430 Broadway, New York, NY 10018

Mounting/Removing a Butt/Pein

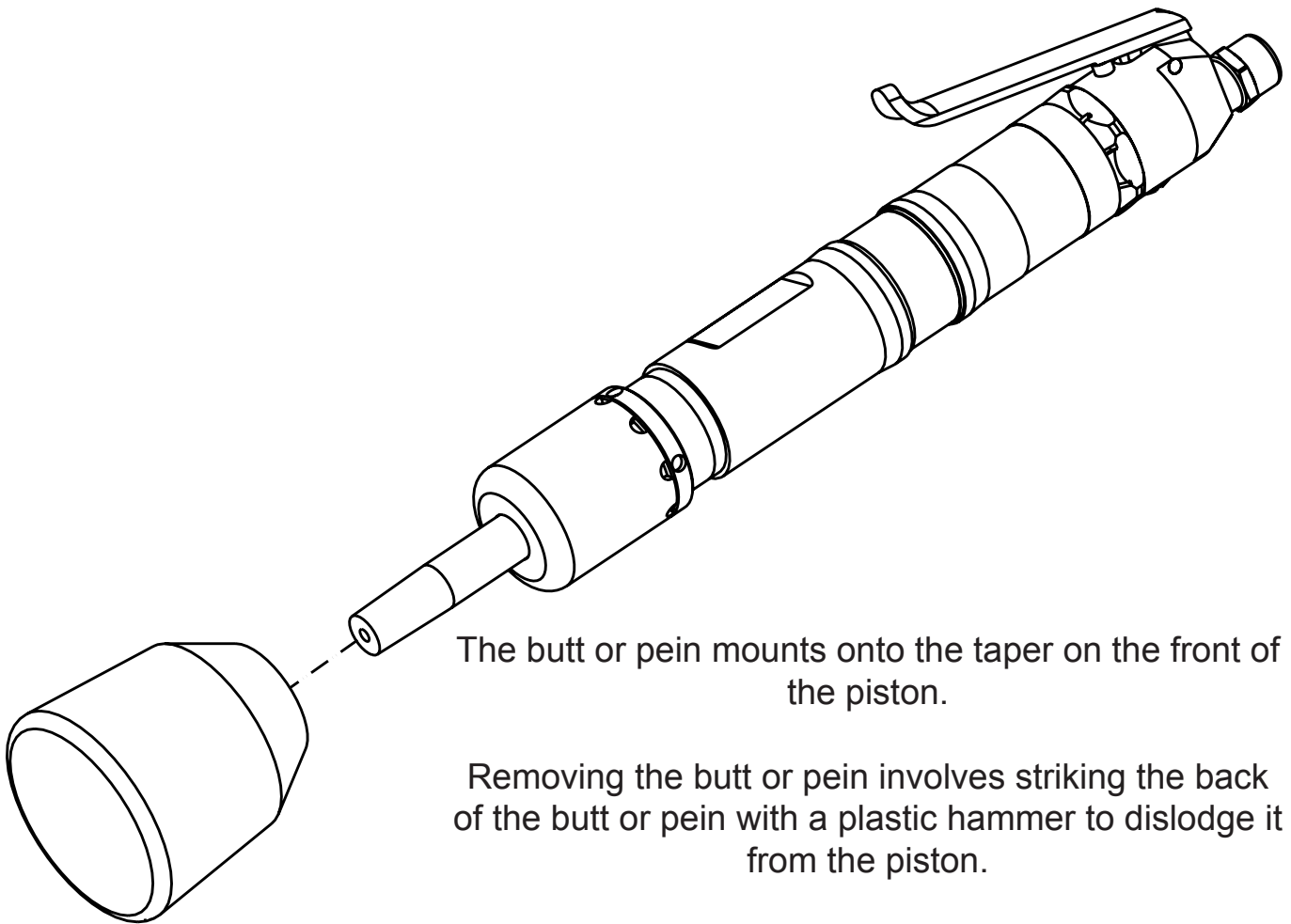

The butt or pein mounts onto the taper on the front of the piston.

Removing the butt or pein involves striking the back of the butt or pein with a plastic hammer to dislodge it from the piston.

Installing the butt or pein involves slipping the part onto the end of the piston and striking the bottom with a plastic hammer so it mounts on the piston.

After installing a new butt or pein, run tool for a full minute away from yourself or anyone else to insure the butt or pein is firmly attached and the tool is functioning properly.



Grinders

- Vertical Grinders
- Horizontal Grinders
- Right Angle Grinders
- Die Grinders
- Extended Grinders
- Bench Grinders

Polishers

- Vertical Polishers
- Horizontal Polishers
- Right Angle Polishers

Saws

Drills

Percussion Tools

- Scalers
- Needle Scalers
- Chipping Hammers
- Rammers

Air Motors



T.C. Service Co.
38285 Pelton Rd.
Willoughby, OH 44094
U.S.A.
Ph: 440-954-7500
Fax: 440-954-7118

© Copyright 2004
All Rights Reserved