

## Horizontal Grinders for 5/8-11 Cone Wheels

### 400GH Series



### 507H Series



### 520H Series



| Max. Rated Speed | Exhaust Direction | Lever Style    | MODEL NUMBER    | Max. Rated Speed | Exhaust Direction | Lever Style    | MODEL NUMBER   | Max. Rated Speed | Exhaust Direction | Lever Style    | MODEL NUMBER    |
|------------------|-------------------|----------------|-----------------|------------------|-------------------|----------------|----------------|------------------|-------------------|----------------|-----------------|
| 20000 RPM        | Side              | Standard Lever | 400GH2S;20000   | 18000 RPM        | Side              | Standard Lever | 507HLS2;18000  | 12000 RPM        | Side              | Standard Lever | 520HLSCW;12000  |
|                  |                   | Safety Lever   | 400GH2SK;20000  |                  |                   | Safety Lever   | 507HKS2;18000  |                  |                   | Safety Lever   | 520HKSCW;12000  |
|                  | Rear              | Standard Lever | 400GH2SR;20000  |                  |                   | Standard Lever | 400GH2SR;18000 |                  |                   | Standard Lever | 400GH2SRK;18000 |
|                  |                   | Safety Lever   | 400GH2SRK;20000 |                  |                   |                |                |                  |                   |                |                 |
| 18000 RPM        | Side              | Standard Lever | 400GH2S;18000   |                  |                   | Standard Lever | 400GH2SR;18000 | Safety Lever     | 400GH2SRK;18000   |                |                 |
|                  |                   | Safety Lever   | 400GH2SK;18000  |                  |                   |                |                |                  |                   |                |                 |
|                  | Rear              | Standard Lever | 400GH2SR;18000  |                  |                   |                |                |                  |                   |                |                 |
|                  |                   | Safety Lever   | 400GH2SRK;18000 |                  |                   |                |                |                  |                   |                |                 |

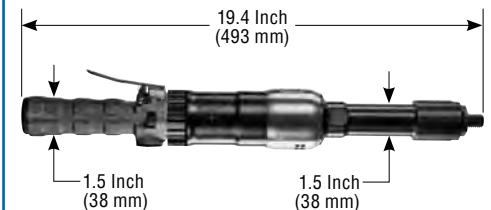
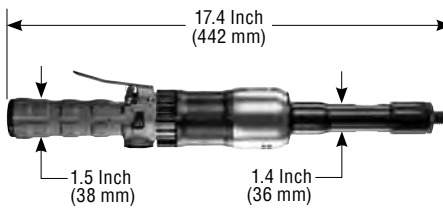
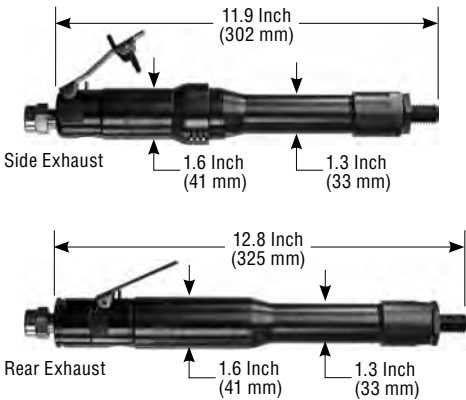

1.2 H.P. (900 W)



35 cfm (16.5 L/s)



1.5 H.P. (1.1 kW)



20 cfm (9.4 L/s) Free Speed  
35 cfm (16.5 L/s) Max



2.0 H.P. (1.5 kW)



20 cfm (9.4 L/s) Free Speed  
40 cfm (18.9 L/s) Max



3.2 Lbs. (1.4 Kg) Aluminum  
3.8 Lbs. (1.7 Kg) Steel



3/8" NPT Inlet  
1/2" (13 mm) Hose Size



6.5 Lbs. (3.0 Kg) Steel Only



1/2" NPT Inlet  
1/2" (13 mm) Hose Size



8.4 Lbs. (3.8 Kg) Steel Only



1/2" NPT Inlet  
1/2" (13 mm) Hose Size

### STANDARD EQUIPMENT

- Tool
- Operating Instructions and Service Manual
- Wrenches (sizes based on options)

### 400GH Series Alternate Options

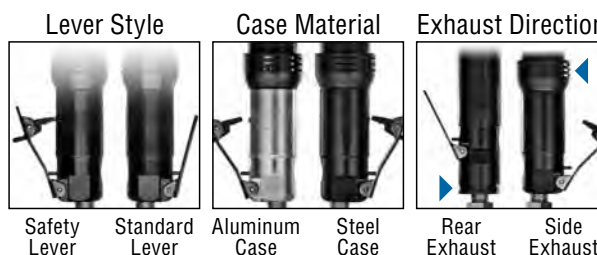

### Cone Wheel Mounting

